

MOSKITO-AMF

Omni-directional outdoor infrared detector



INSTALLATION AND USE MANUAL

15.08-M:3.0-H:SE-05v2-14-F:2.0

MOSKITO is an outdoor sensor designed for the perimeter protection of a building with an efficiency never seen before: it integrates in the inside 6 passive infrared PIR heads.

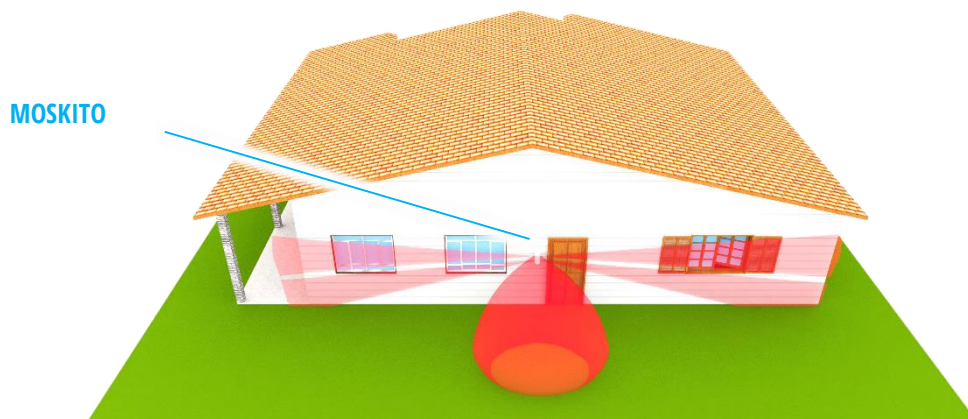

A double IR barrier on both sides of the sensor creates a protection of doors and windows in front of the building for a total length of about 12 + 12 meters. Two additional IR heads, furthermore, guarantee the detection of approaching from frontal side up to 8 meters, avoiding potential elusion attempts of the lateral protection. The lateral protection on each side is made of two IR heads working with AND logic, which create two curtain detection areas with an opening of 10° and range up to 12 meters each .

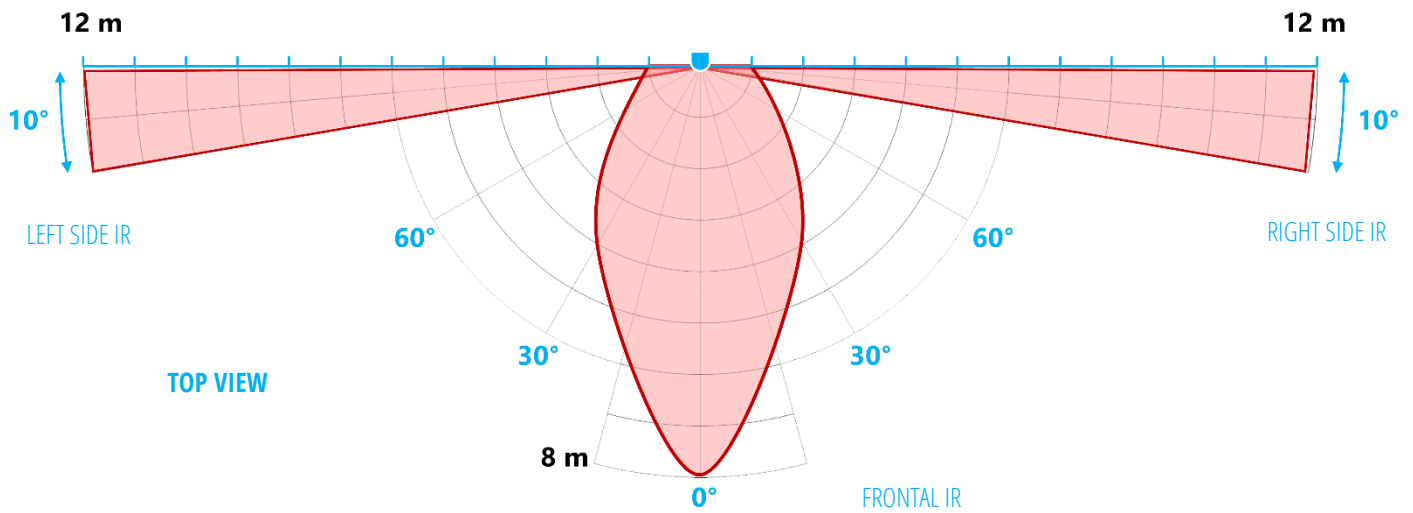

The detection areas are independently adjustable each other, by geometry (lower PIR head orientable vertically), and by sensitivity (trimmer). On frontal side, instead, there is a volumetric detection area with 180° opening and range up to 8 m, with sensitivity adjustment (trimmer). The two detection sides can generate each one an independent zone alarm towards the control panel, and they can be combined with the frontal side using the Anti-elusion function, which, once detected the movement on frontal side, requires only one lateral PIR head to generate alarm.

In ideal environmental conditions, it is possible to have independent alarm from each side, although it is not recommended. The frontal detection is not suitable in all environmental conditions, with risk of false alarms.

When the sensor is set to have alarm from frontal side, all the sides (right, left and frontal) are independent (PIR heads of each side are in AND).

Each side of Mosquito has a couple of IR detection heads: upper head (horizontal or far detection) and lower head (landward or near detection). When in NORMAL, the sensor sends alarm only if both heads of one side are violated (AND).

Left and right lower heads can be oriented on three positions: this allows to avoid false alarms due to far crossings (i.e.: vehicles) or animals.

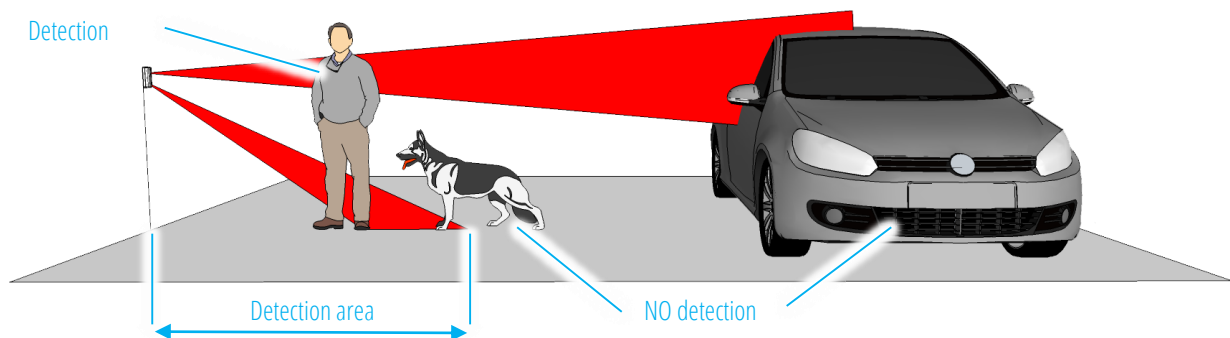

Provided with anti-removal tamper based on double-accelerometer (without microswitch) and a protection visor, the detector allows all functioning parameters setting by a practical series of dip-switch. TEST function independent for each side with led and acoustic buzzer for a simple and quick installation. It can be mounted at a height between 100 and 140 cm and it has an impact resistance at maximum level (IK-10).

Auto-adjustment of parameters to outdoor temperature.

**READ CAREFULLY THIS MANUAL BEFORE INSTALL YOUR NEW ALARM SYSTEM.
KEEP THIS MANUAL FOR FUTURE REFERENCE.**

**ONLY QUALIFIED TECHNICIAN MUST INSTALL THIS DEVICE.
INSTALLER MUST FOLLOW CURRENT REGULATIONS.**

**DO NOT INSTALL THE CONTROL PANEL IN VERY HUMID OR WARM ENVIRONMENT OR NEAR TO BATHS,
SINKS, ETC.**

**THE MANUFACTURER SHALL NOT BE LIABLE FOR ANY IMPROPER USE OF THE PRODUCT, INCORRECT
INSTALLATION OR FAILURE TO COMPLY WITH INSTRUCTIONS OF THIS MANUAL AND THE LAW REGARDING
ELECTRICAL SYSTEMS.**

INDEX

TECHNICAL	4
PRECAUTIONS	8
DETECTION AREA	10
SETTINGS	11
ANTI-MASKING ON/OFF (DIP1)	11
ANTI-ELUSIONE ON/OFF (DIP2)	12
SIDES ADJUSTMENT (DIP3, DIP4, DIP5)	12
NORMAL / WALK-TEST MODES (DIP7)	12
BUZZER (DIP6)	13
INCLINOMETER TAMPER (DIP8)	13
WALK TEST	14
SENSITIVITY/RANGE ADJUSTMENT	15
LOWER LATERAL IR HEADS INCLINATION	17
RANGE ADJUSTMENT OF LATERAL IR HEADS (RV2 AND RV3 TRIMMER)	18
RANGE ADJUSTMENT OF FRONT IR HEADS (RV1 TRIMMER)	18
FRONT SIDE ADJUSTMENT	19
LEFT SIDE ADJUSTMENT.....	19
RIGHT SIDE ADJUSTMENT	20
TAMPER	21

TECHNICAL

MAINBOARD

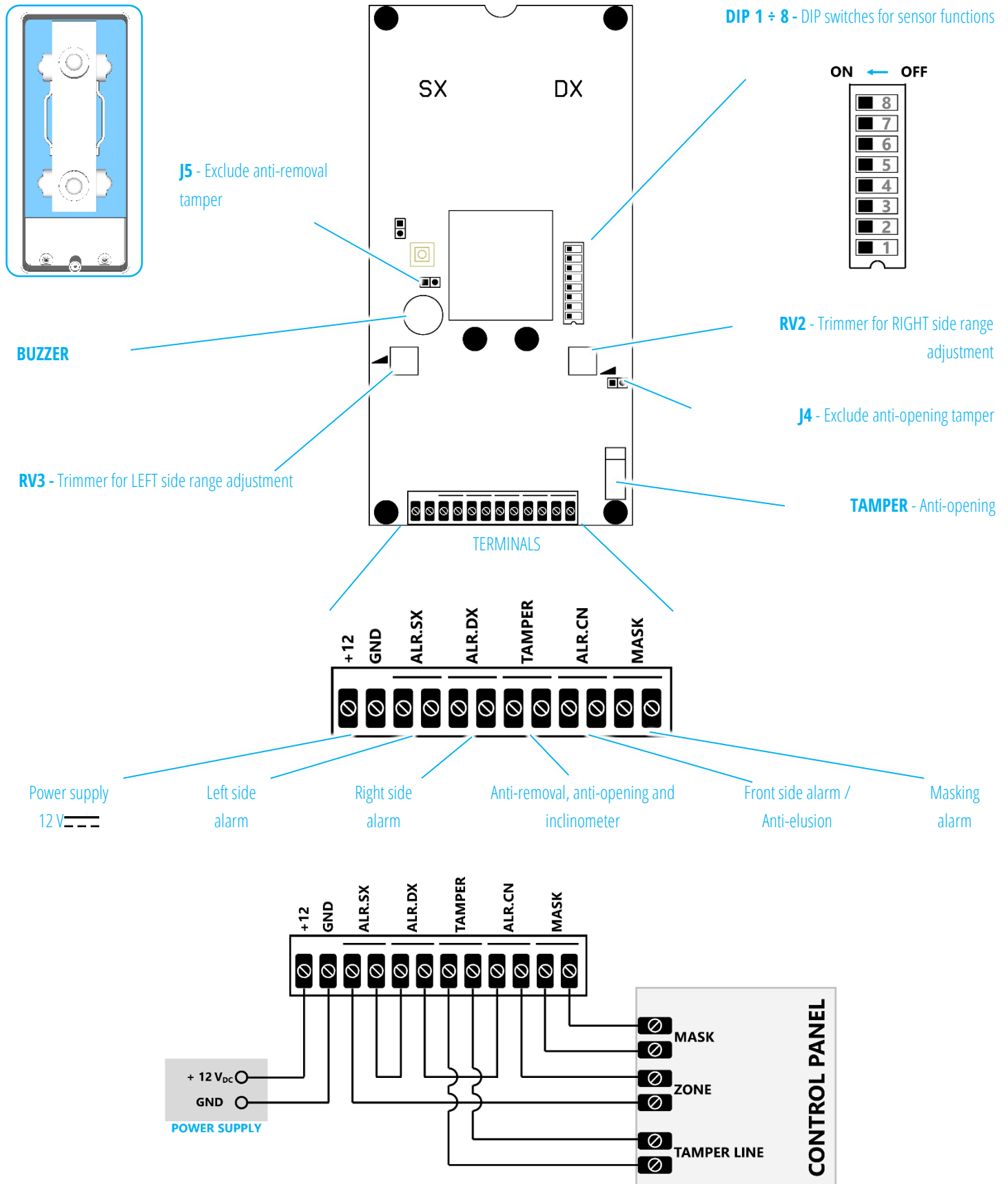

Connection example: one zone on control panel

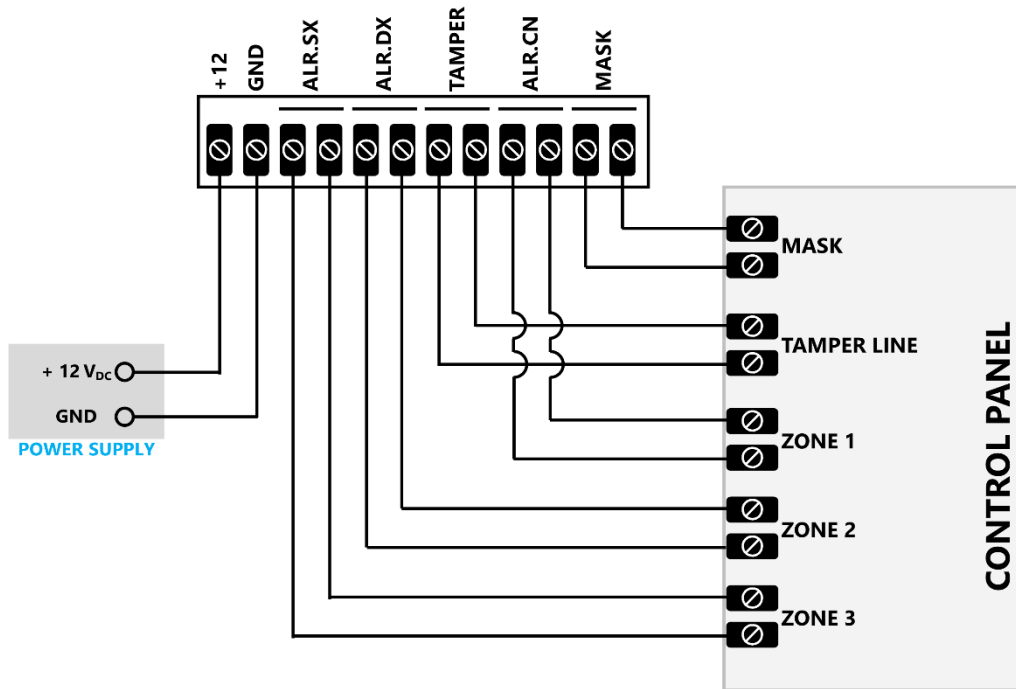

Connection example: three zones in control panel

NOTE ABOUT ANTI-ELUSION: when the anti-elusion function is active (DIP2 = ON) a detection from only the frontal side does not activate any alarm output.

In case - after a detection from frontal side - there is a lateral detection, will be activated the lateral alarm output and the front alarm output **ALR.CN** (this one inform about the elusion attempt).

FRONT BOARD

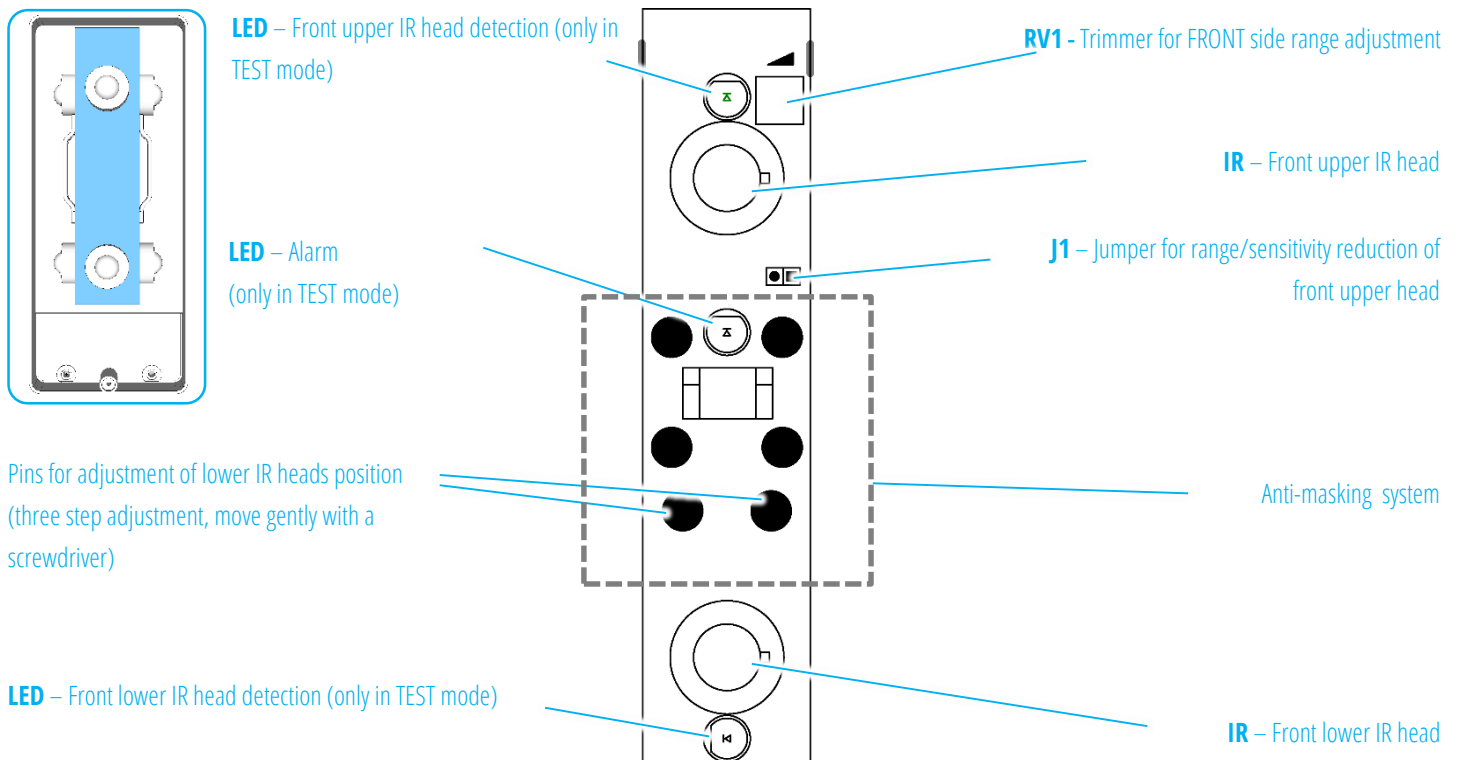

RIGHT BOARD

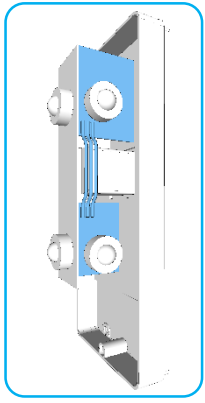

IR – Right upper IR head

IR – Right lower IR head

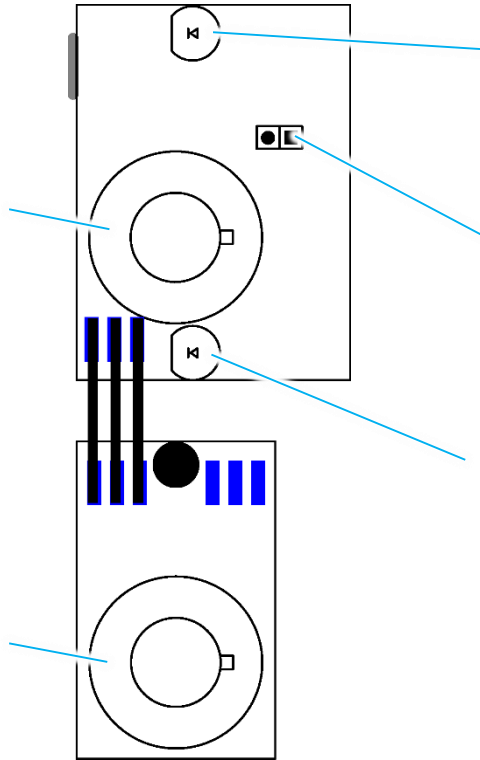

LED – Right upper IR head detection
(only in TEST mode)

J2 – Jumper for range/sensitivity reduction
of right upper head

LED – Right lower IR head detection
(only in TEST mode)

LEFT BOARD

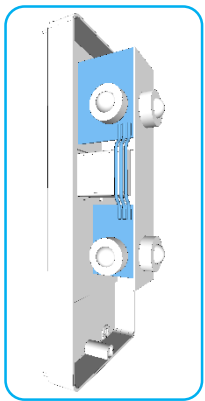

LED – Left upper IR head detection
(only in TEST mode)

J3 – Jumper for range/sensitivity reduction
of left upper head

LED – Left lower IR head detection
(only in TEST mode)

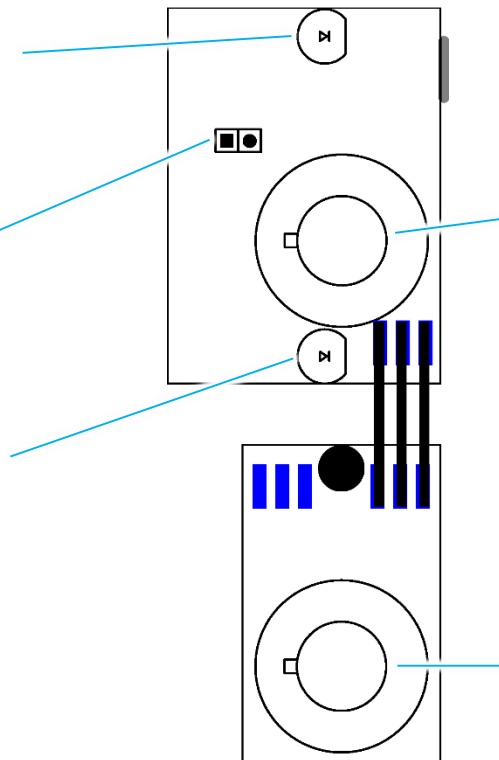

IR – Left upper IR head

IR – Left lower IR head

Power	Power source	12 V 
	Absorption *	About 14 mA
Timings	Boot time	About 90 seconds
	WALK-TEST time	20 minutes (at the end the detector back to NORMAL mode even if DIP7 = ON)
Technology	Three sided infrared detector	6 infrared heads
Installation height		100 ÷ 140 cm
Detection Area	Side range (right / left) *	Max: about 12 m
		Min: about 3 m
	Front range *	Max: about 8 m
		Min: about 2 m
	Side area (right / left)	Upper and lower lobe: about 2,5 m @ 12 m
Front area	One lobe, width max about 3 m @ 4 m	
Detection speed	Crossing detection	0,3 ÷ 2,0 m/s
Outputs	All the outputs are OptoMOS (40 V _{bc} / 100 mA MAX) Outputs are N.C. at powered sensor, and they open if no power source	Right side alarm (terminal ALR.DX) Left side alarm (terminal ALR.SX) Front side alarm / Elusion (terminal ALR.CN) Masking alarm (terminal MASK) Tamper (terminal TAMPER)
Signals	Detection LED *	6 red LEDs (one LED each IR head)
	Alarm LED *	1 blue LED for alarm
	Acoustic *	Integrated buzzer, emits different sounds for: heads detection, tamper, change mode, learning, anti-mask
Temperature	Working	-40 ÷ +70 °C
	Compensation	-20 ÷ +50 °C
Humidity		95 %
Case	Material	ABS, anti UV
	Dimension (H x W x D)	190 x 85 x 75 mm
	IP protection grade	IP54
	Impact resistance	IK10 (impact of a 5 kg body from 40 cm)

* All the data are approximate, for sensor in NORMAL mode, installation height of 120 cm and operating temperature of 21 °C

THE MAX RANGE DEPENDS SIGNIFICANTLY ON ENVIRONMENT TEMPERATURE

PRECAUTIONS

1

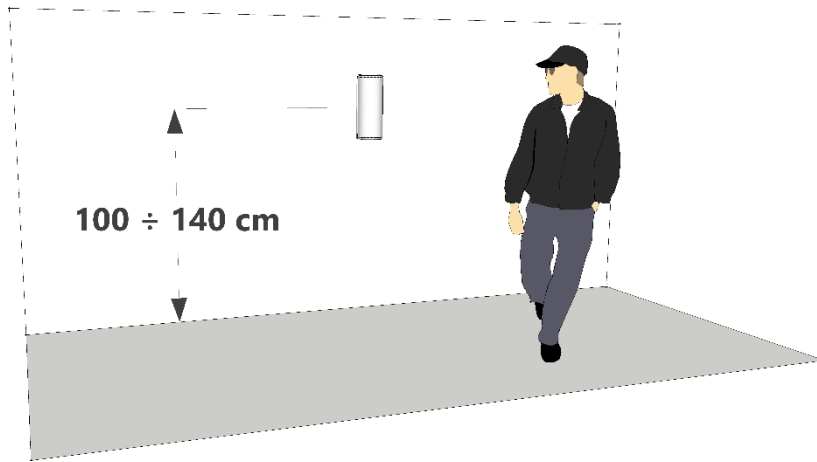

Installation height must be between 100 cm and 140 cm.

2

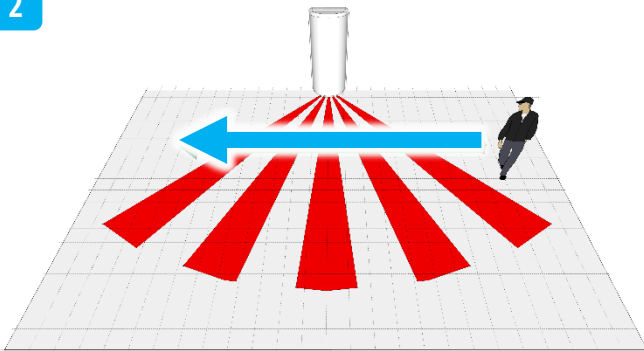

YES

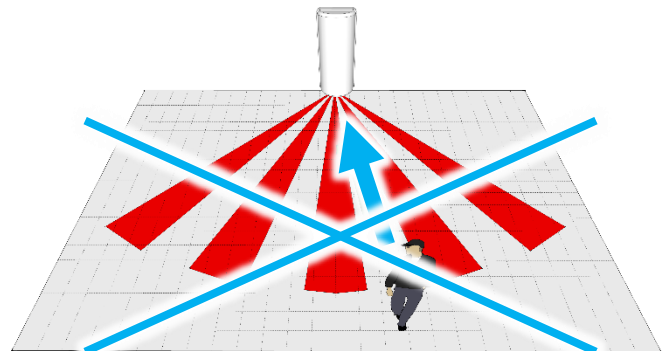

NO

To obtain certain detection, the sensor must be installed so that the intruder crosses the IR zones. The detection range is reduced approaching towards the front of the sensor.

3

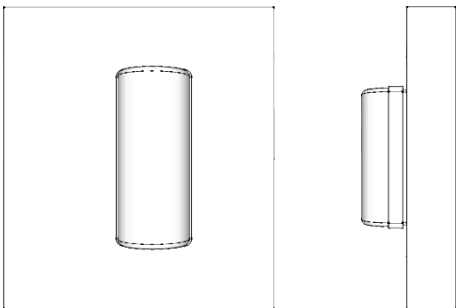

YES

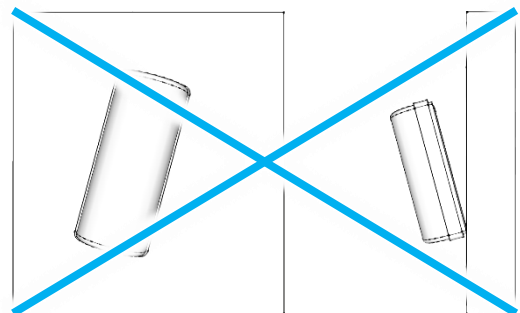

NO

Mount the sensor vertically, without front and side tilt. If the sensor is mounted at an angle relative to the ground, the detection is altered and the anti-removal protection (inclinometer) intervenes

4

NO

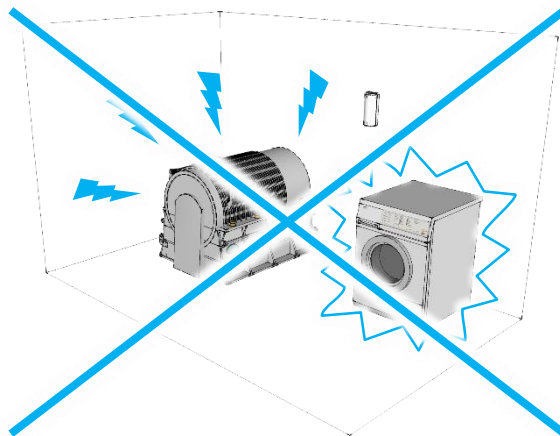

Do not install the detector in an environment with electromagnetic interference or vibrating objects

5

NO

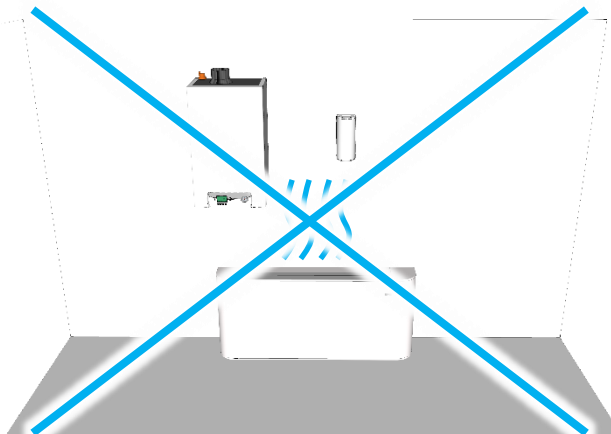

Do not install the detector near to heating systems or air conditioner.

6

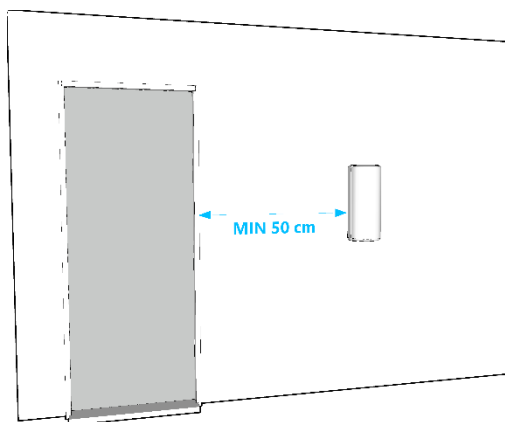

It is recommended to install the detector at least 50 cm from the nearest gate.

DETECTION AREA

Left and right detecting sides are 12 meters length range each, reaching 24 meters of linear protection, with 10° opening angle on horizontal plane.

FRONT VIEW

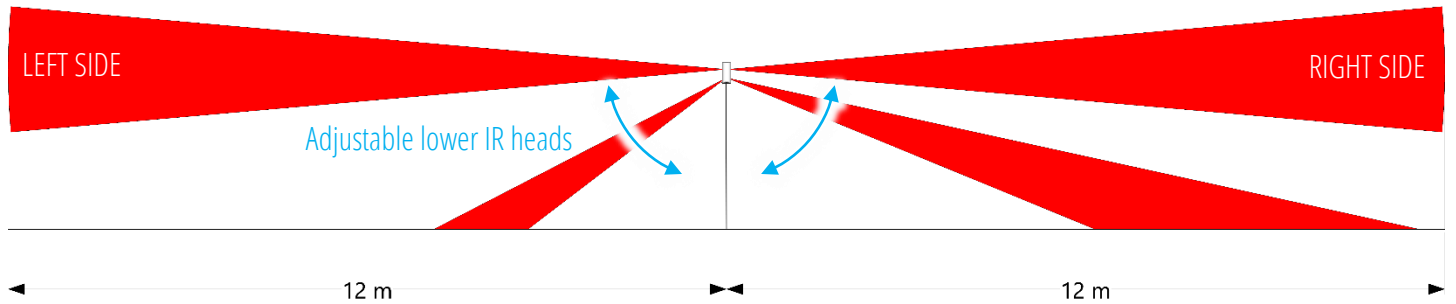

TOP VIEW

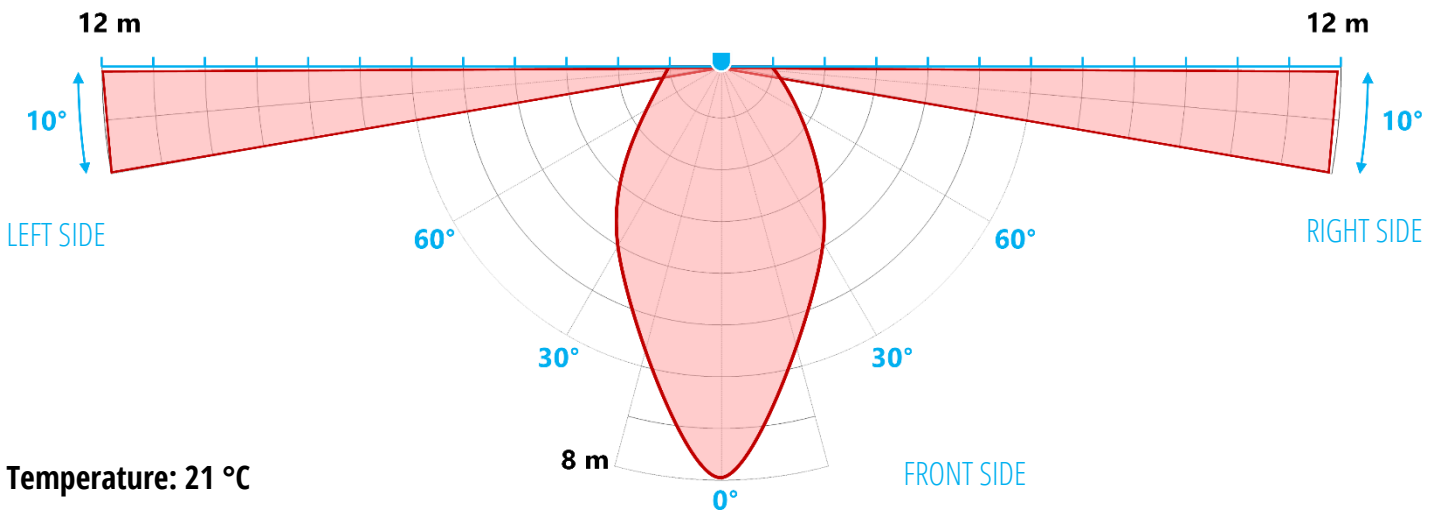

Temperature: 21 °C

Installation height: 120 cm

Any side detection (front, left or right) will generate alarm.

When the detector works in TEST mode, the alarm is signalled by the BLUE LED on (alarm transmission LED) and by acoustic sounds (if sounds are enabled, different for each side):

- One "beep" = front side
- Two "beeps" = right side
- Three "beeps" = left side

SETTINGS

The 8 way DIP SWITCH controls function settings of the detector:

DIP SWITCH

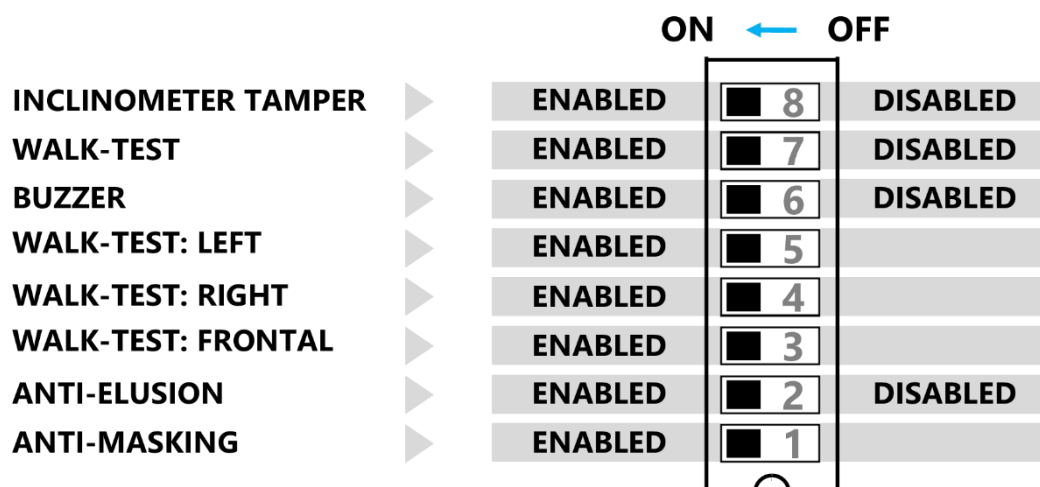

ANTI-MASKING ON/OFF (DIP1)

The anti-masking system protects 24h/24 the sensor against attempts to cover it (blinding) in order to prevent the detection of violations.

⚠ The anti-masking cannot work properly without the cover on the sensor.

DIP1 = OFF Anti-masking disabled: no anti-masking protection

DIP1 = ON Anti-masking enabled: the sensor activates the **MASK** alarm output in case of masking attempts (cover the sensor to avoid detection).

In normal mode, the mask detection is not immediate but requires the masking remains for a certain time (more than a minute).

To quickly test the anti-masking, set the sensor in WALK-TEST (DIP7 = ON) and mask it (the cover of the sensor must be placed on). During test the anti-masking detection requires a few seconds.

To exit from WALK-TEST without generate masking alarm (it may be caused by the installer while setting DIP) it is recommended to act as follows: **DIP1 = OFF** (disable anti-mask) → **DIP7 = OFF** (set Normal mode) → Wait about 10 seconds → **DIP1 = ON** (enable anti-mask) → Place on the cover of the sensor.

⚠ The **MASK** alarm output stays active until the sensor is masked.

⚠ The anti-mask protection is always active (when DIP1 = ON) even if the control panel is disarmed.

⚠ Keep a clear zone of **about 30 cm from the sensor** in which a person cannot stay for more than one minute and there are no opened doors, hanging clothes, furniture!

ANTI-ELUSION ON/OFF (DIP2)

DIP2 = OFF Anti-elusion disabled: the sensor generates alarm if both IR heads of any side (left, right, front) detect:

- Detection of both left side heads → activate output **ALR.SX**
- Detection of both right side heads → activate output **ALR.DX**
- Detection of both front side heads → activate output **ALR.CN**

DIP2 = ON Anti-elusion disabled: the sensor generates alarm if both IR heads of left or right sides detect (as in NORMAL mode) Furthermore, alarm is generated if both front IR heads detect and then any single IR head of left or right sides detect (in this case, when the side alarm output becomes active, the front alarm output **ALR.CN** becomes active too)

- Detection of both left side heads → activate output **ALR.SX**
- Detection of both right side heads → activate output **ALR.DX**
- Detection of both front side heads → no output activated
- Detection of both front side heads + one head of left side → activate outputs **ALR.SX + ALR.CN**
- Detection of both front side heads + one head of right side → activate outputs **ALR.DX + ALR.CN**

⚠ Adjust properly the front side sensibility and range to avoid unwanted detections.

SIDES ADJUSTMENT (DIP3, DIP4, DIP5)

Select which side to adjust / perform walk test using DIP3, 4 and 5. It is possible to enable more than one side at same time. These DIP act only if sensor is in WALK TEST mode (DIP7 = ON), otherwise they are ignored.

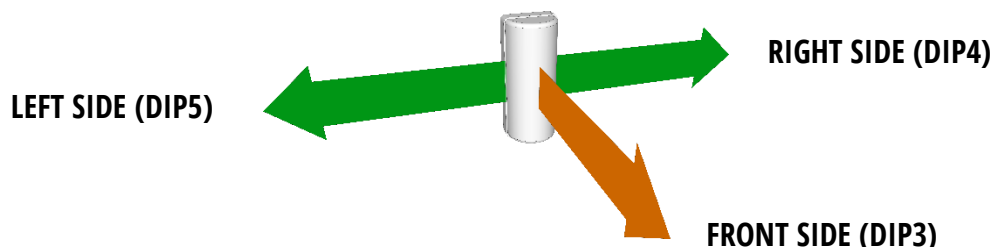

DIP3 = ON **Front side** adjustment: enables the two front IR heads for adjustment / walk test

DIP4 = ON **Right side** adjustment: enables the two right IR heads for adjustment / walk test

DIP5 = ON **Left side** adjustment: enables the two left IR heads for adjustment / walk test

NORMAL / WALK-TEST MODES (DIP7)

DIP7 = OFF **NORMAL**: the sensor uses all the settings made during the last adjustment (in TEST mode). It is the normal working mode of the sensor (steady operation).

In NORMAL mode, the trimmer adjustment has no effect.

The LEDs are always off. The buzzer can be enabled by DIP6.

DIP7 = ON **ADJUSTMENT/TEST:** allow to perform the adjustment and the WALK TEST

To adjust the range set the DIP 3, 4 and 5 to select the side to work on. It is possible to enable more than one side at same time. During adjustment, disabled sides will not detect and the detector reads only the changes of trimmers combined to enabled sides.

The max time for adjustment/walk test is 20 minutes, after which the sensor back to NORMAL mode (even if DIP7 is not set to OFF). To restart the TEST mode, switch DIP7 to OFF then to ON again.

BUZZER (DIP6)

DIP6 = OFF **NO SOUNDS:** the buzzer is off, the detector will not emit sounds *

DIP6 = ON **SOUNDS ENABLED:** the buzzer is active, the detector emits sounds: detection, tamper and status change *

In WALK-TEST mode (DIP7 = ON), the buzzer emits some “beep” at detection of any side (one “beep” = front side, two “beep” = right side, three “beep” = left side)

In NORMAL mode (DIP7 = OFF), the buzzer emits at each alarm and tamper events (use only for monitor or verification).

* The detector automatically exit from WALK-TEST after 20 minutes signalling with some “beep” (even if the buzzer is disabled)

INCLINOMETER TAMPER (DIP8)

Electronic protection obtained thanks to digital inclinometer.

As soon as the sensor is tilted by 30° (any direction) it is generated a tamper alarm .

To enable/disable this protection:

DIP8 = OFF Inclinometer tamper disabled

DIP8 = ON Inclinometer tamper enabled

 See the “TAMPER” paragraph for more details.

WALK TEST

DIP7 = ON	Sensor in TEST mode: ALARM LED enabled
------------------	--

DIP3 = OFF	Walk-test on all sides
DIP4 = OFF	
DIP5 = OFF	

In this mode, walking in front of or side to the sensor, each time any IR head detects intrusion the combined LED switch on.

UPPER LEFT head detection LED

UPPER FRONT head detection LED

UPPER RIGHT head detection LED

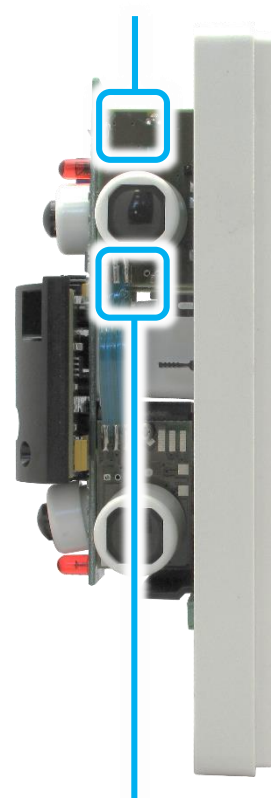
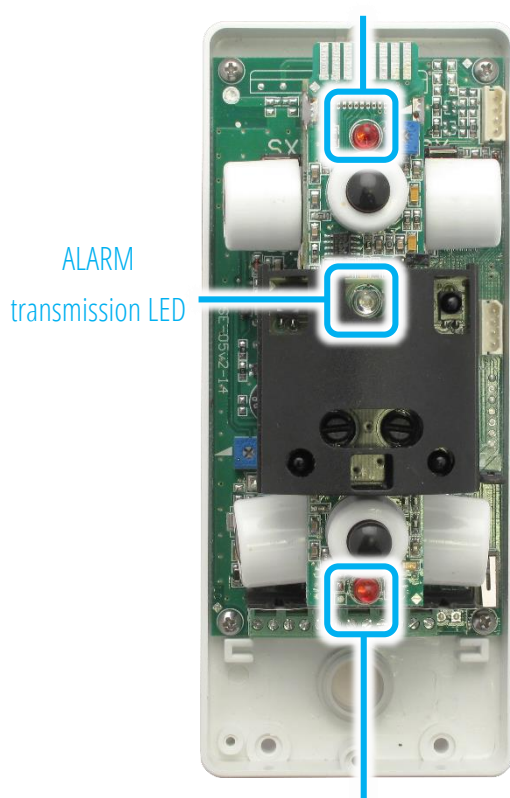

LOWER LEFT head detection LED

LOWER FRONT head detection LED

LOWER RIGHT head detection LED

The alarm is signalled with the blue LED and (if the buzzer is enabled by DIP6 = ON) different sounds from buzzer:

- One "beep" = front side
- Two "beep" = right side
- Three "beep" = left side

Mosquito backs automatically to NORMAL mode after 20 minutes: the buzzer (even if disabled) emits a special "beep" sequence (long – short – long – short...) to advice the status change.

The walk test allows to verify anti-elusion (if enabled, DIP2 = ON).

It is possible to test the anti-masking system: mask the sensor for at least 3 seconds (with its cover placed on).

SENSITIVITY/RANGE ADJUSTMENT

DIP7 = ON

THE DETECTOR ENTER IN ADJUSTMENT MODE: ALL THE CHANGES ARE IMMEDIATELY APPLIED, THE VALUE OF TRIMMERS IS READ AND THE IR HEAD LEDS ARE ENABLED.

TO HAVE THE ACOUSTIC SIGNALLINGS FROM BUZZER SET DIP6 TO ON.

TO CHECK THE REAL RANGE OBTAINED, ALWAYS PLACE THE COVER OVER THE SENSOR AFTER EACH ADJUSTMENT.

TO FACILITATE THE SENSITIVITY ADJUSTMENT, USE THE DIP 3, 4 AND 5 TO SELECT THE SIDE TO WORK ON, AVOIDING INTERFERENCES FROM OTHER SIDES.

TRIMMER FOR RANGE: ARE PLACED NEAR THEIR COMBINED SIDE AND ARE USED TO ADJUST THE RANGE/SENSITIVITY.



RV3
Trimmer for LEFT
range adjustment

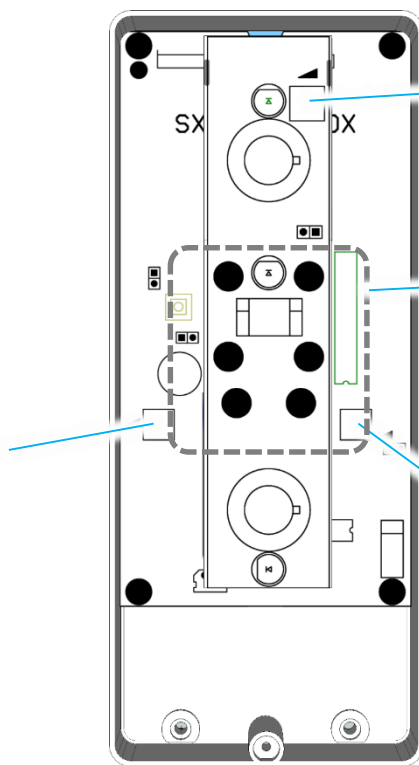

RV1
Trimmer for FRONT
range adjustment

Anti-masking system

RV2
Trimmer for RIGHT
range adjustment

UPPER AND LOWER IR HEADS OF THE SIDE ARE ALWAYS ADJUSTED TOGHETER.

EACH SIDE HAS A JUMPER (SEE NEXT FIGURE) TO REDUCE THE RANGE AND SENSITIVITY OF UPPER HEADS.

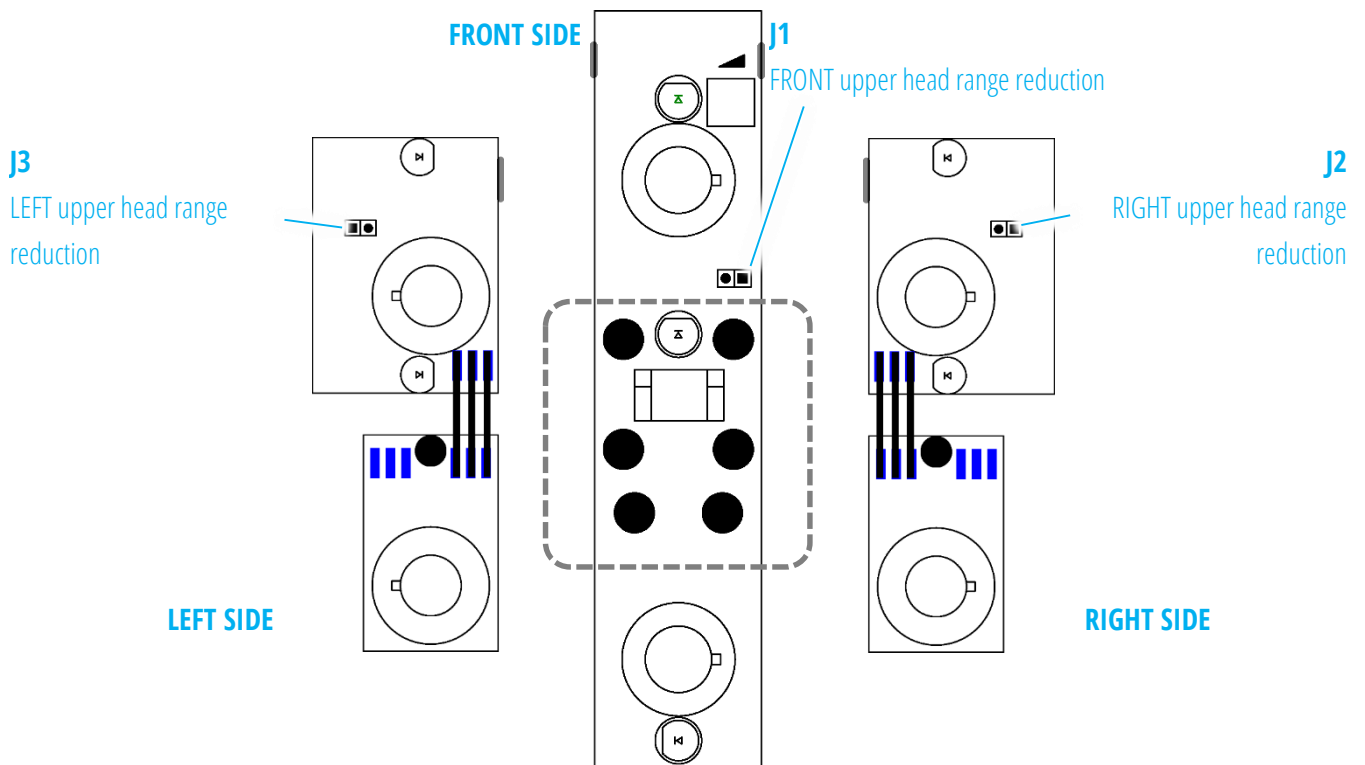

WHEN THE JUMPER IS CLOSED, THE RANGE AND SENSITIVITY OF THE UPPER HEAD ARE REDUCED AT ABOUT 50% OF MAXIMUM VALUE (THE MAX VALUE DEPENDS FROM TRIMMER REGULATION).

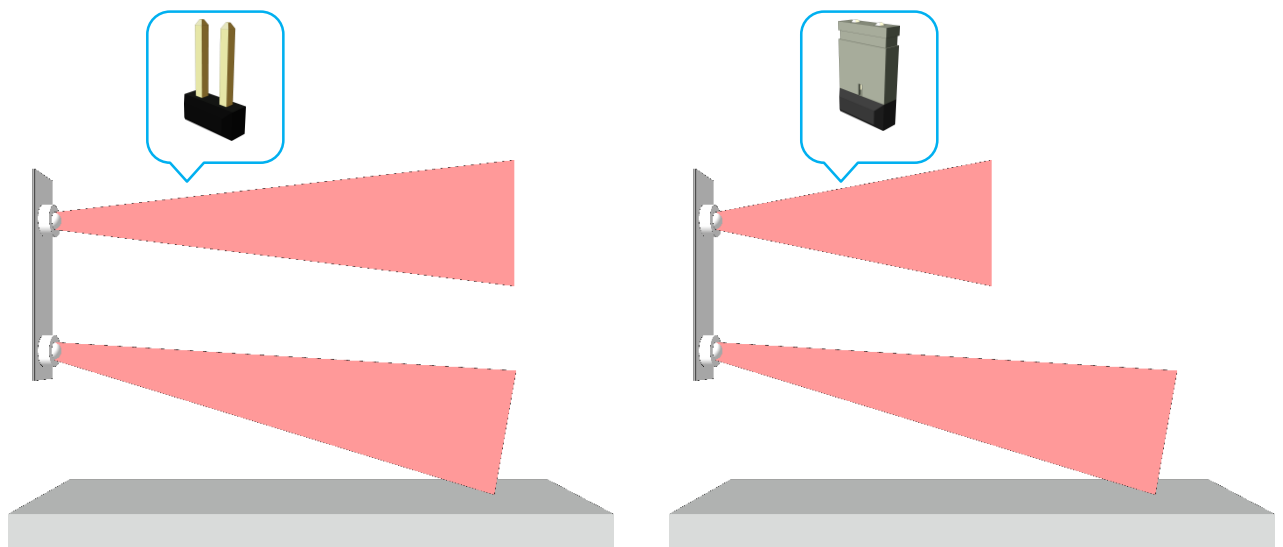

**THIS REDUCTION DOES NOT AFFECT THE LOWER HEADS RANGE.
THE TRIMMERS ALWAYS ADJUST BOTH UPPER AND LOWER HEADS RANGE OF COMBINED SIDE.**

FOR ADJUSTMENT FOLLOW NEXT INSTRUCTIONS

LOWER LATERAL IR HEADS INCLINATION

The lateral heads inclination allows to adjust the range and depends on the sensor installation height. The adjustment has three steps (3 positions) according to the following scheme, acting on combined pins.

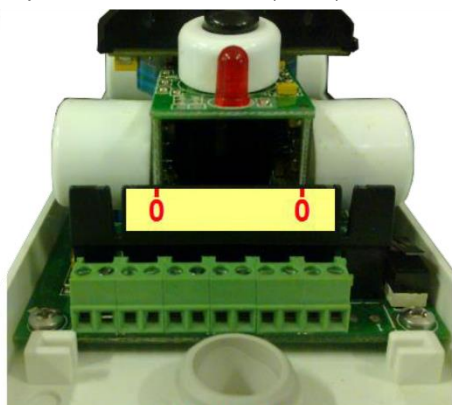

POSITION 0

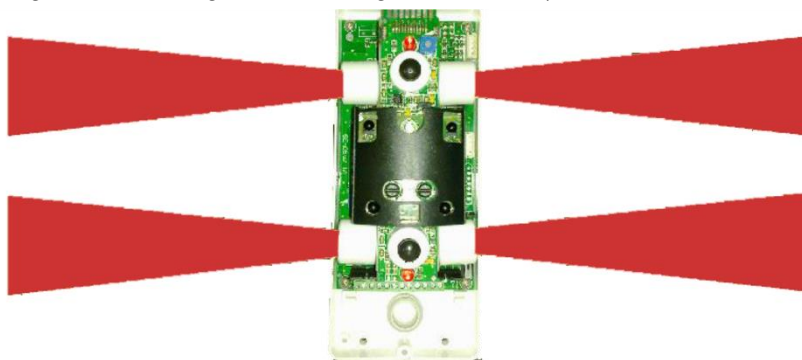

DO NOT USE THIS POSITION

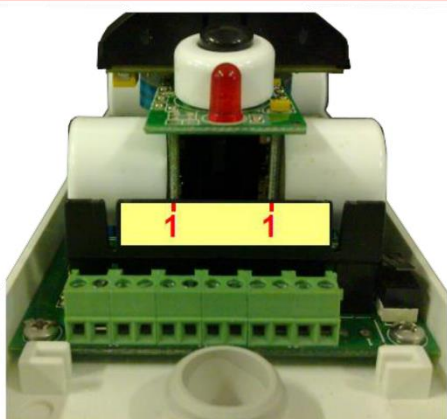

POSITION 1

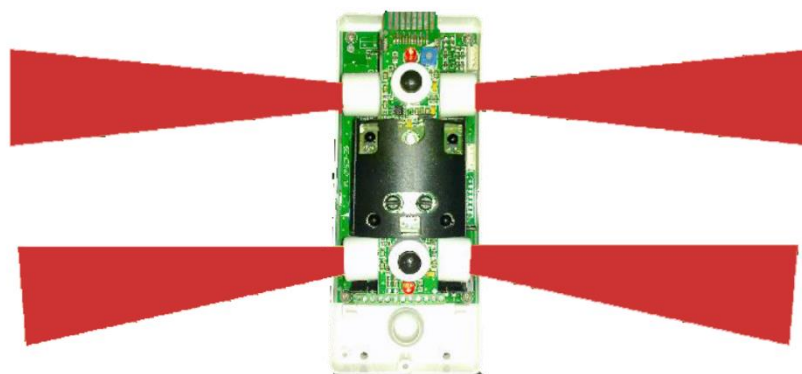

FIRST POSITION

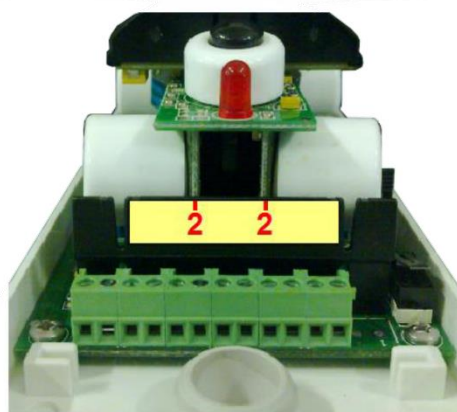

POSITION 2

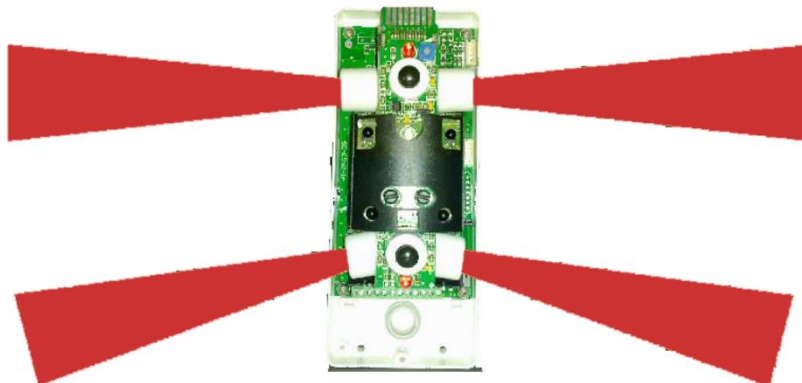

SECOND POSITION

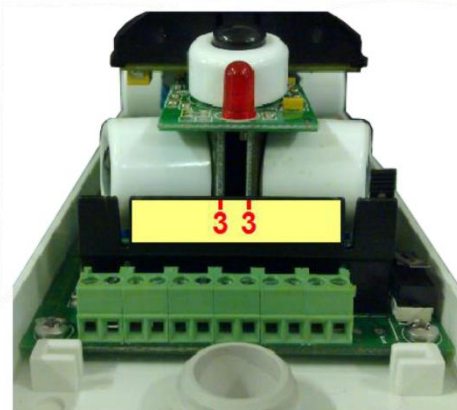

POSITION 3

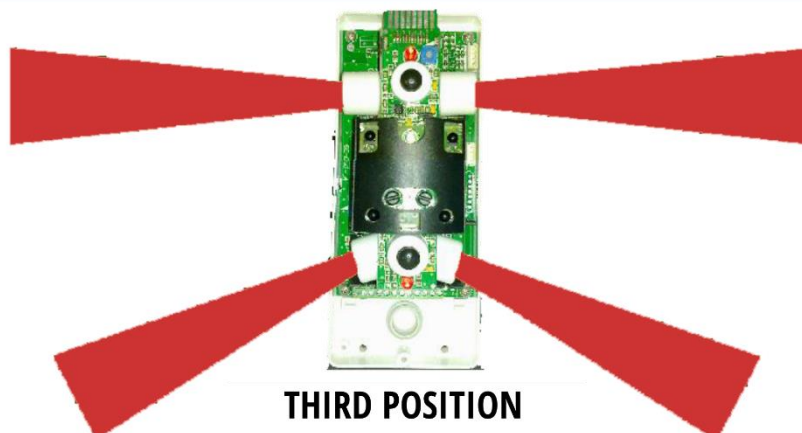

THIRD POSITION

IT IS POSSIBLE TO ADJUST THE TWO SIDE DIFFERENTLY

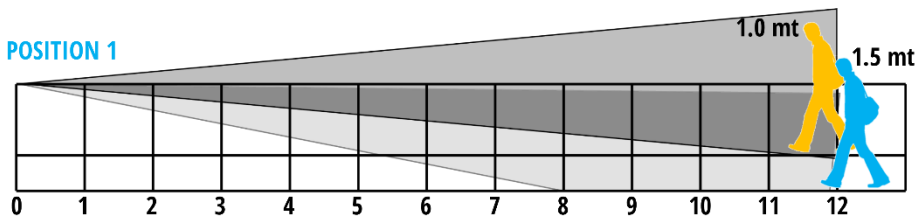

TEST AFTER EACH ADJUSTMENT!

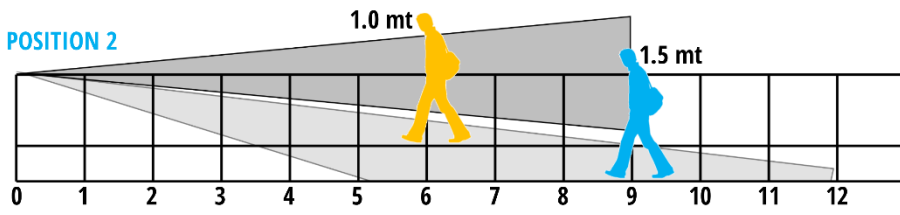

LATERAL HEAD ADJUSTMENT

INSTALLATION HEIGHT	1.0 mt	1.5 mt
RANGE POSITION 1	12 mt	12 mt
RANGE POSITION 2	6 mt	9 mt
RANGE POSITION 3	3 mt	5 mt

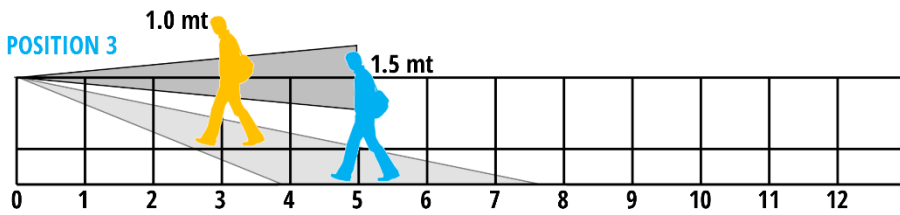

RANGE ADJUSTMENT OF LATERAL IR HEADS (RV2 AND RV3 TRIMMER)

Side trimmer position (RV2 and RV3)	Range with head in position 1	Range with head in position 3
<p>MIN MAX MAX RANGE</p>	about 12 m	about 3 m
<p>MIN MAX MIN RANGE</p>	about 6 m	about 1,5 m

NOTE: data refers to sensor installed at 100 cm height and at operating temperature of 21 °C

RANGE ADJUSTMENT OF FRONT IR HEADS (RV1 TRIMMER)

Front trimmer position (RV1)	Range without anti-elusion
<p>MIN MAX MAX RANGE</p>	about 8 m
<p>MIN MAX MIN RANGE</p>	about 2 m

NOTE: data refers to sensor installed at 100 cm height and at operating temperature of 21 °C

FRONT SIDE ADJUSTMENT

DIP7 = ON	Sensor in TEST mode: ALARM LED enabled
------------------	--

DIP3 = ON	Walk-test only for front side
DIP4 = OFF	
DIP5 = OFF	

Adjust the range using the **RV1** trimmer (this trimmer adjust contemporary the sensitivity of both upper and lower IR heads).

Start with low sensitivity, that is the trimmer RV1 is completely turned counter-clockwise. Increase progressively the sensitivity with RV1 (turning clockwise) until obtain the detection only in the area to be protected.

Place the cover and verify the sensor does not detect intrusions over of the wanted area.

If the sensor detects over the wanted area, decrease the sensitivity. If necessary, it is possible to reduce the upper head range by closing the **J1** jumper and adjust the RV1 trimmer.

Perform all the tests with the cover on sensor!

At the end set DIP3 and DIP7 to OFF

LEFT SIDE ADJUSTMENT

DIP7 = ON	Sensor in TEST mode: ALARM LED enabled
------------------	--

DIP3 = OFF	Walk-test only for left side
DIP4 = OFF	
DIP5 = ON	

Adjust the range using the **RV3** trimmer (this trimmer adjust contemporary the sensitivity of both upper and lower IR heads).

Adjust the lower head position (inclination downward: position 1, ..., position 3): the side range decrease and increase immunity to false alarms (caused by small pets, reflections or perturbation in infrared field).

Start with low sensitivity, that is the trimmer **RV3** is completely turned counter-clockwise.

Increase progressively the sensitivity with **RV3** (turning clockwise), if necessary adjust the lower IR head tilt.

Place the cover and verify the sensor does not detect intrusions over of the wanted area.

If the sensor detects over the wanted area, decrease the sensitivity and/or adjust the lower IR head tilt. If necessary, it is possible to reduce the upper head range by closing the **J3** jumper and adjust the **RV3** trimmer, until both heads cover the same range.

Perform all the tests with the cover on sensor!

At the end set DIP5 and DIP7 to OFF

RIGHT SIDE ADJUSTMENT

DIP7 = ON	Sensor in TEST mode: ALARM LED enabled
------------------	--

DIP3 = OFF	Walk-test only for right side
DIP4 = ON	
DIP5 = OFF	

Adjust the range using the **RV2** trimmer (this trimmer adjust contemporary the sensitivity of both upper and lower IR heads).

Adjust the lower head position (inclination downward: position 1, ..., position 3): the side range decrease and increase immunity to false alarms (caused by small pets, reflections or perturbation in infrared field).

Start with low sensitivity, that is the trimmer **RV2** is completely turned counter-clockwise.

Increase progressively the sensitivity with **RV2** (turning clockwise), if necessary adjust the lower IR head tilt.

Place the cover and verify the sensor does not detect intrusions over of the wanted area.

If the sensor detects over the wanted area, decrease the sensitivity and/or adjust the lower IR head tilt. If necessary, it is possible to reduce the upper head range by closing the **J2** jumper and adjust the **RV2** trimmer, until both heads cover the same range.

Perform all the tests with the cover on sensor!

At the end set DIP4 and DIP7 to OFF

TAMPER

The sensor is protected against tampering attempts by two controls: cover anti-opening and anti-removal (this one uses both inclinometer and electro-mechanic technologies).

When the sensor is in TEST mode, a tamper event is signalled by 5 slow “beeps” sequence and blue alarm LED (buzzer must be enabled, set DIP6 = ON).

ANTI-OPENING

Protection against the cover opening.

To enable/disable this function act on **J4** jumper:

- **J4** = closed → Tamper disabled
- **J4** = opened → Tamper enabled

ANTI-REMOVAL

Double protection against sensor removal from installation place: electro-mechanic and inclinometer.

Electro-mechanic

Protection activated by opening of the tamper switch on the back of the case (normally closed because the sensor is fixed on the wall).

To enable/disable this protection act on **J5** jumper:

- **J5** = closed → Back tamper disabled
- **J5** = opened → Back tamper enabled

Inclinometer

Electronic protection obtained by digital inclinometer on board.

As soon as the sensor is tilted of about 30° (any direction), the tamper alarm starts.

To enable/disable this protection act on **DIP8**:

- **DIP8** = OFF → Inclinometer tamper disabled
- **DIP8** = ON → Inclinometer tamper enabled

Disable this protection only if the detector is subject to vibrations, installed not in vertical position or during installation and test.

(empty page)

(empty page)



This device meets the R&TTE requirements (European Union)
This manual may be subject to change without notice

MADE IN ITALY