

SERIES SL - AUTOMATION FOR SLIDING GATES
101/SL424EBSS (AVAILABLE UNTIL DECEMBER 2014)

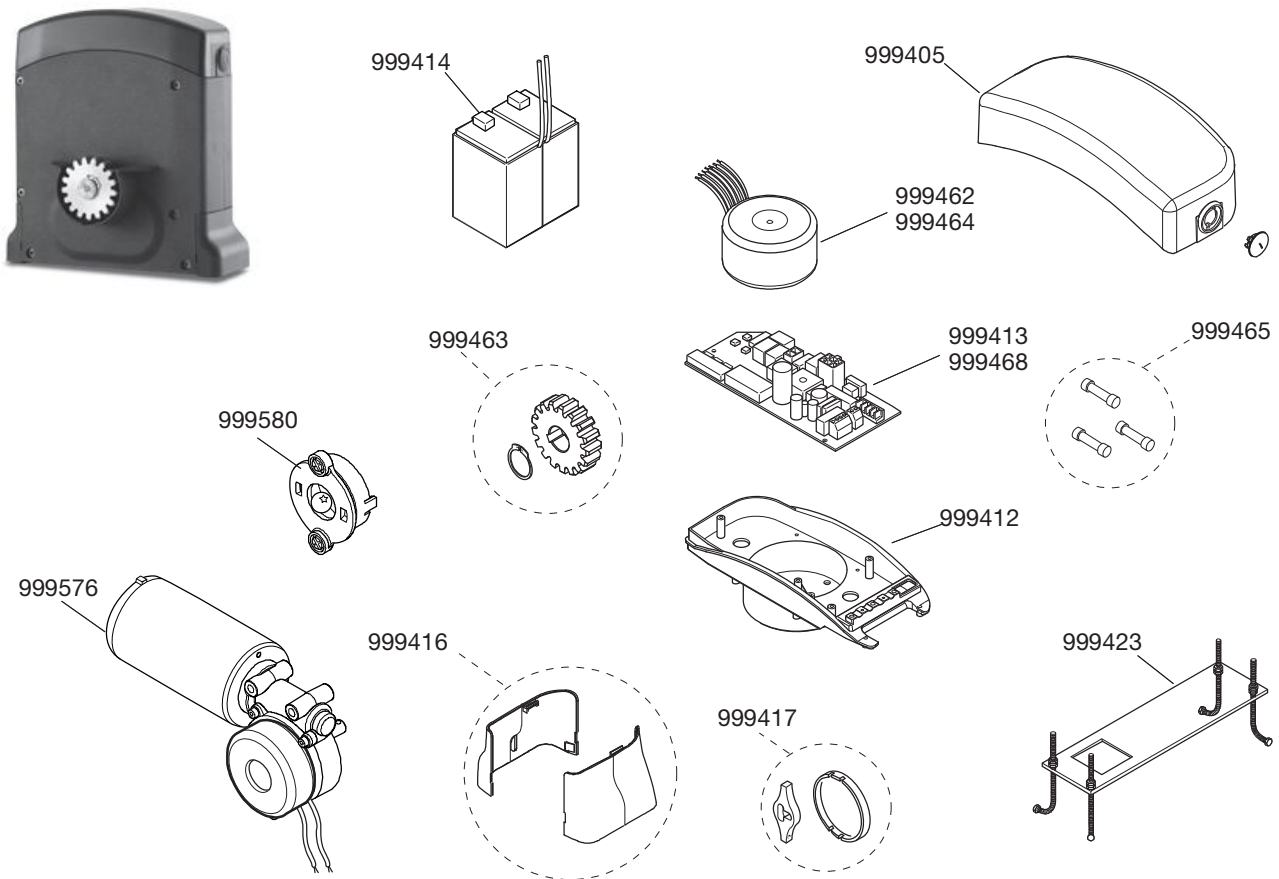

PART NR.	PCS	DESCRIPTION
999405	1	Upper cover
999412	1	Electronic card support well
999413	1	Electronic card for SL424EBSS (ver. "dIP 13")
999414	1	Lead battery 12V x 2 = 24V 2.2 Ah
999416	1	Side covers
999417	1	Manual release mechanism key + cover
999423	1	Motor base plate in metal
999462	1	Transformer ZUT130VA-SL (ver. "dIP 13")
999463	1	Pinion
999464	1	Transformer ZUT130VA-SL-1 (ver. "dIP 15")
999465	1	Set of 20 fuses 1,6A - 3,15A - 10A
999468	1	Electronic card for SL424EBSF (ver. "dIP 15")
999576	1	Motor unit + optical encoder
999580	1	Manual release unit