

CUSTOMER SERVICE
CARDIN ELETTRONICA

SERIES PL - SELF-POWERED ELECTROMECHANICAL PARKING SPACE PROTECTION
600/PARKSUN - 600/PARKLINE

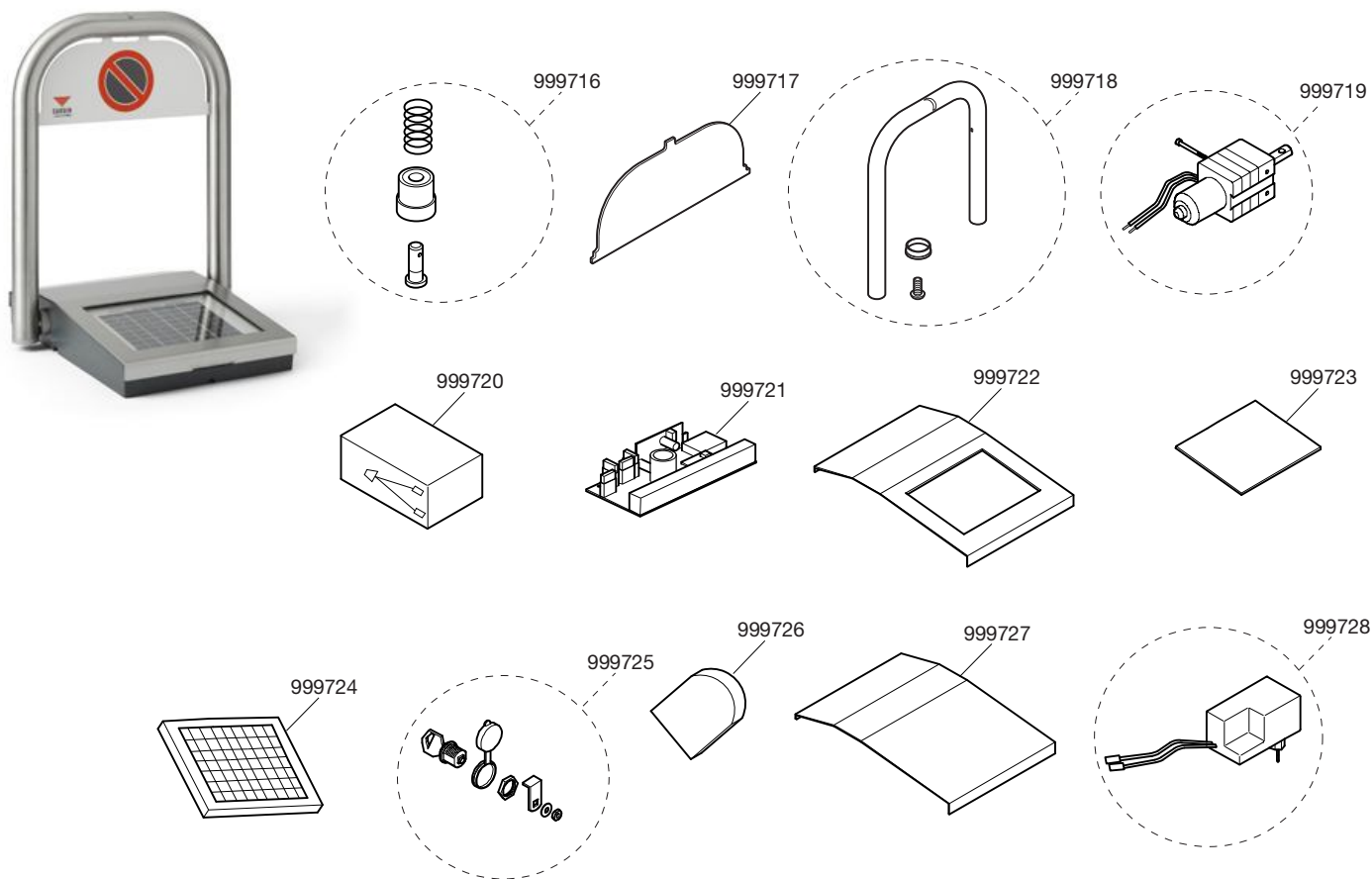

* To order the Electronic card you must indicate the circuit number printed on the back off the card, as well as the product code e.g.:

product code **999721/ 0000A** circuit code

PART NR.	PCS	DESCRIPTION	product code	circuit code
999716	1	Mechanical shock absorber spring		
999717	1	Parking prohibited sign		
999718	1	Stainless steel arch		
999719	1	Motor unit 12V		
999720	1	lead buffer batteries 12V		
999721	1	Electronic card		
999722	1	Cover (PARKSUN)		
999723	1	Glass cover (PARKSUN)		
999724	1	Solar panel (PARKSUN)		
999725	1	Lock + key		
999726	1	Movement indicator led		
999727	1	Cover (PARKLINE)		
999728	1	Battery charger (PARKLINE)		