



PHOTON SYSTEM

Installation Guide

(rel. 7.4)

General description of the system

The Photon system produced by Deitech in its basic configuration, is made of two bars absolutely identical (Fig. 1). The bars are placed at the two ends of the area to be controlled thus creating a true "infrared barrier"; the barrier are connected with just one cable to a hub (Fig. 2). This is assembled in the Control Unit and from there it controls the whole system. The barriers are used for both transmission and reception of the beams, work in couple and exists in different versions: from 50 to 200 cm height, with or without heater, with maximum range varying from 25 to 50 meters. They have all with the same design; are made of an

aluminium body with a black polycarbonate cover and two caps of the same colour. On the "ROTAX" cap (Fig. 3) you can find the connection on the terminal blocks and the ROTAX hinge for the orientation of the beams. On the "NUMBER" cap (Fig. 4) there is the selector where you find the ID number to assign to the barrier and, in those models who are predisposed for the heater, the terminal blocks for power supply. Through a four wire cable (plus shield) the barriers will be connected to the hub; the connection could be a star or in series so that it

can easily adjust to the different installation requirements. The hub controls the correct functioning of the barriers, allow the configuration of the system and concentrate the connexion with the control panel. The hub will manage up to a maximum of four couples. Very important to say is that the four couples can be installed even in the same area and the beams will not interfere between themselves. The four couples can be of different heights and different range but the barriers of each couple must be the same. For each couple the hub will allow to set different working distances and will manage single stand-by time, while the other working functionalities will be common between the four couples. The output for the control panel (alarm, tamper, disqualification, failure) are common for all the couples managed by the hub. If it's needed to differentiate the alarms (one for each couple) there is an expansion module to be installed in the hub. (Fig. 20). If the installation will require more than four couples or different configurations (i.e. two couples "internal" and two "external"), then more hub are needed.



Fig. 1

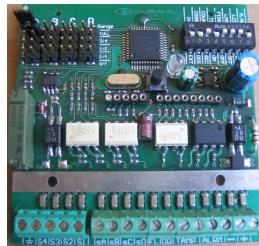

Fig. 2 - hub



Fig. 3 – rotax cap

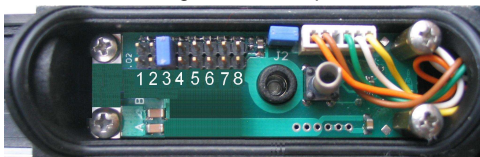

Fig. 4 – number cap

The bars

It's absolutely fundamental to install the couple of barriers properly, each couple must be placed in order to protect the passage trough which an intruder could pass. In order to determine the correct highness of the bar, it must be taken into consideration that the first beam is placed at 20 cm from the end of the barrier and that between the other beams there are 25 cm. the barrier can be placed upside down to connect the hub either from above or from below, but it is mandatory that each couple is installed in the same position. All the Photon barriers have a registered system by Deitech that allows a correct horizontal alignment of the beams (ROTAX). This system will enable the installer to

install the barrier on surfaces that not necessarily are placed in front (Fig. 5). Oblique installations can than be easily made, (Fig. 6) with a maximum angle of 90° between the walls i.e. the barriers can be installed on the same wall (Fig. 7). The ROTAX (Fig. 17) is the rotating element that has to be used in order to direct all the beams in the range +/- 90°.

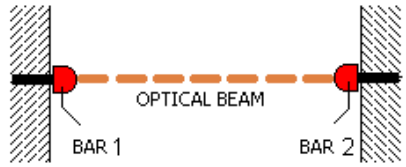

Fig. 5

The bars are equipped with two tamper systems. The first one (that cannot be deactivated) is located on the cap's opening and goes in alarm every time the cap is open.

The second will reveal the removal of the bar from the surface on which it is installed and can be deactivated if not used. Inside the bar there are two red led that can flash if the hub is set on "LED ON"; one will signal a tamper alarm i.e. that at least one of the four tampers is open, the other one when the barrier is in "alarm" condition.

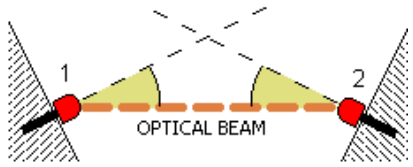

Fig. 6

The ice can divert the direction of the beams; it is possible to order a version of barrier with integrated heating system (the not "heated" ones cannot be modified later).

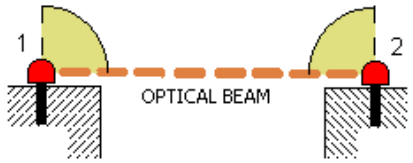

Fig. 7

These bars, that must be used along with the proper heating module, are suggested for external installations and anyway in cold and humid environments. The system administered by a thermostat, guarantee the functioning up to -20°C.

Leaning of the wires to the bars

After having set where the bars have to be placed, it will be necessary to position the connecting wires between the hub and the barriers. In a standard installation (bars positioned at a maximum of 200-300 mts from the hub) a standard 4 wire cable (two for power supply 0,75 mm² 2 for the serial communication 0,22 mm²) and shield.

The number of possible connection typologies is quite wide and for each one of that the maximum length of the cable may vary.

Fig. 23 represents some examples with the maximum cable length. Warning the maximum length of a cable connected to a single barrier is 1000 mts.

For the connection of the wirings, there are waterproof interconnection boxes to be used (Fig. 22) equipped with tamper.

These can be walled in or buried and contain a terminal blocks that allows to derive from the bus two wires for the couple. The terminal blocks alone can also be supplied if there are already interconnection boxes installed.

Whenever the tamper device of the interconnection boxes is used, the cable will be made of 6 wirings (2 for the power supply 0,75 mm², 2 for the serial connection 0,22 mm² and two for the tampers 0,22 mm²) plus shield.

Fig. 24 represents an example of a connection of a complete system.

If the bars are the heated version, then you will have to refer to the instructions supplied with them.

Fixing the bars

The bars must be fixed on walls or supports that should be as much as possible flat and plumb; in case it is advisable to use plies to correct and to fill the surface making it flat. If there is no intention to use the anti-removal tamper it is sufficient to lean the bar on the support and after having plumbed it, mark the holes for the screws trough the button-hole of the two caps. While tightening the screw the bars will not be bended, otherwise the correct functioning could be harmed.

Anti-removal activation (Optional)

The anti-removal tampers are two waterproof push button which are integrated in the rear of each

cap and are encased in order to avoid easy tampering. In order to keep each tamper duly pressed it is sufficient a head of a screw that stands out for about 3/4 mm. The anti-removal system requires a certain precision of installation. For this purpose a mask is supplied that shows the exact point where the plug has to be inserted. The head of its screw will stand out for minimum 3 mm and not more 4 mm. If plies have been used, then the distance of the screw's head must be adjusted according to the needs. Once the bars have been fixed, remove the jumper J1 on the ROTAX cap and J2 from the NUMBER cap and verify with a tester positioned on the two pins of the J1 and/or J2 jumpers that the contact is "closed"; if it appear as "open" than that mean that the screw does not stand out enough. Warning do not protrude the head more than 4 mm in order not to damage the micro-switch.

The connection of the wirings in the bars

The connection ccordion happens ccordion to this steps:

- 1) prepare the wire (Fig. 8 A / B).
- 2) Insert the wire in the chock (Fig. 9).
- 3) Fold the shield backwards and lean it on the tie holder (Fig. 8 C / D).
- 4) Block with a strip the wire to the tie holder (Fig. 8 E / F).
- 5) Cut, shear and fix the 4 wirings into the terminal blocks and block the chock (Fig. 10).

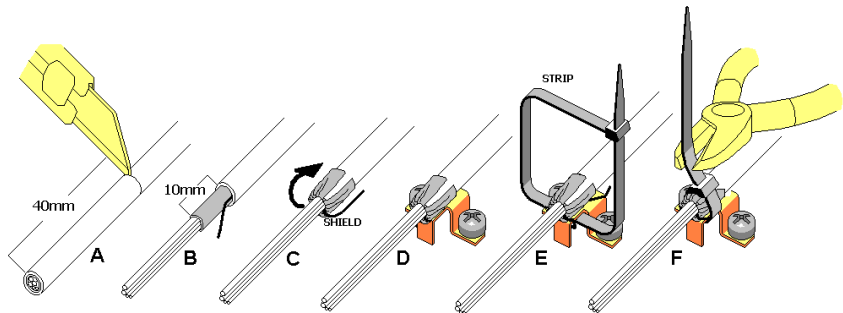

Fig. 8

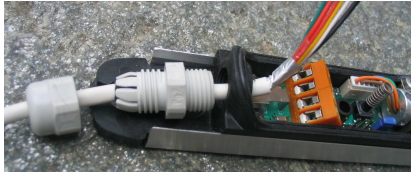

Fig. 9

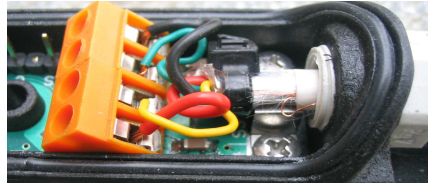

Fig. 10

Settings of the bars

In the bars there are two settings to do. The first one will enable the anti-removal tamper. Whenever you want to activate it you will have to remove the two jumpers that are placed in the NUMBER and in the ROTAX caps. The other relates with assigning the ID number to each bar. Each Hub can manage up to four couples (i.e. 8 bars) and each bar must be precisely identified with a univocal number. This will be set through a group of jumper that can be found in the cap "NUMBER" (Fig. 11). The ID number must be set as follows: 1 and 2 for the first couple ("A" zone) 3 and 4 for the following ("B" zone) 5 and 6 for the third ("C" zone) and 7 and 8 for the fourth ("D" zone).

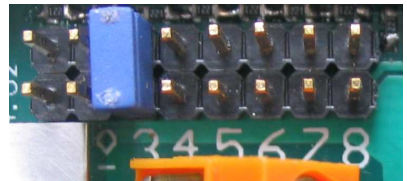

Fig. 11

The hub

The connection between the Hub and the bars

The connection with the bars can be made only through the 5 dedicated vice of the hub (Fig. 25). Do not connect the bars to different supplies than the one foreseen and be very careful not to invert the serial poles S2 and S3.

Fig. 24 represent an example of the connection of a complete system.

Vice description:

S1 = Negative power supply vice (0 V) wire min. 0,75 mm²

S2 = RS 485 vice "A" pole wire min. 0,22 mm²

S3 = RS 485 vice "B" pole min 0,22 mm²

S4 = Positive power supply (+12V) wire min 0,75 mm²

The connection between the Hub and the control panel

The hub is made in such a way that it can be installed in the Control Panel. Use the holes foreseen in the Hub for its fixing. The connection will be made by the cabling of the wires between the terminal blocks of the Hub and the Control Panel.

It is strongly advised to use at least two wires of minimum 0,75 mm² for the power supply.

Fig. 24 represent an example of the connection of a complete system.

The terminal blocks of the Hub toward the Control Panel

<i>Terminal block</i>	<i>Functionality</i>	<i>Type of contact</i>
Input SA SB SC SD	To be connected to the Control Panel if you intend to manage the stand-by separately. They can also be connected all together in order not to give separate stand by to the different couples. When the barriers are on stand by the beams are not active (this means energy saving and a less component consumption) but the tampers and the failure are active.	Active Zone = free or at gnd De activated Zone = + 12 Volt
Output Failure	Normally open it is close at ground if malfunctioning is detected (failure, wiring interruption etc.)	Normal = Free Failure 100 Ohm at gnd
Output Disqualification	It active only if in "extern" functioning, normally open it is closed at ground when due to limited visibility conditions (fog, heavy rain) the barriers cannot work properly (during the disqualification the alarm is not given). It re-open as soon as the condition goes back to normality.	Normal = Free Failure 100 Ohm at gnd
Output Tamper	Normally closed. It is open if one of the tamper is activated.	Closed = 20 Ohm Open = Infinite
Output Allarm	Normally closed, it is open when the system detect an interruption of the beam between a couple of barrier.	Closed = 20 Ohm Open = Infinite
Input 12 Volt	Power supply, the Hub is supplied and in turns it supplies all the barriers connected to it.	From) to 16 Volt DC Max 0,6 A (Hub + 8 bars)

Setting of the hub

The hub allows to centralize the configuration of the couples installed. Through the jumper selector (Fig. 25) it is possible to set the working distance for each couple, while through the dip-switch selector (Fig. 25) it is possible to set the common parameters for all the couples.

<i>Dip-Switch</i>	<i>Functionality</i>
M.All (Memory alarm) (On / Off)	It shows if in the bars the alarm led must stay lighted once the alarm is happened (this status will persist until the stand by is deactivated).
Leds (On / Off)	Activate the lighting of the led on the barriers (Alarm and Tamper)
Last (On / Off)	<p data-bbox="300 370 538 722">It deactivate the last or the first beam for each couple. This is useful in case there are animals that could start the alarm. Deactivating the first beam (or the last if for installation cause the barrier is installed upside down) you will not have about 45 cm of protection (Fig. 12 and Fig. 13). Do not deactivate both at the same time.</p> <div data-bbox="546 370 1048 715"> </div>
First (On / Off)	
Tst / Op. (Test/Operate)	During the installation you will have to use “TEST” in order to make a correct alignment. In this operational status the system will exclude some features that would make this operation more difficult. During the operative Status it always must be on “OPERATE”.
Count / Sec. (Count/Security)	In COUNT mode the alarm is given only for the time of real obstruction. A typical use could be for elevators, controlled gates etc. In SECURITY mode the alarm is given and maintained for about 2 seconds and this is the typical use for anti intrusion.
Cross/Dir. (Cross/Direct)	<p data-bbox="300 945 602 1298">It shows if the beams must be direct (Fig. 14) or crossed (Fig. 15) The habilitation of the crossed beams highly increase the protection (if the bars are the 25 mts ones it can be applied only if the minimum distance is 3 mts while for the 50 mts one the limit is 9 mts) The use of crossed beams is anyway to be use with caution in external environment. You can not set off for both switches (Hub will signal failure).</p> <div data-bbox="617 945 1037 1251"> </div>
Int / Ext. (Internal/External)	The mode “EXTERNAL” must be selected only if you need a compensation of the beams when there are visibility problems (fog). For internal installation it is suggested to select “INTERNAL”.

Jumper																
Range	<p>For each of the four zones (denominated “A” “B” “C” “D”) you will have to set the value of the power of the beams according to the distance in which the couple of barriers are installed (“Full”, $\frac{3}{4}$, $\frac{1}{2}$, and $\frac{1}{4}$). Moreover if the jumper of a certain zone is not present that mean that that zone is not present or it must remain inactive. Fig. 16 shows how different power can be set for each zone: Zone “A” and “B” maximum power, zone “C” minimum power and Zone “D” not installed Jumper not connected). If the jumper is inserted in a zone where there is no barrier the Hub will signal failure.</p> <p>Warning after having modified the jumper positioning you have to push the reset button on the hub otherwise the modification will not active until the following restart of the system.</p> <p>Range of functioning based on the type of barrier employed:</p> <table border="1"> <thead> <tr> <th>Jumper selector</th> <th>$\frac{1}{4}$</th> <th>$\frac{1}{2}$</th> <th>$\frac{3}{4}$</th> <th>full</th> </tr> </thead> <tbody> <tr> <td>25 mts bars</td> <td>0-6 mts</td> <td>6-12 mts</td> <td>12-18 mts</td> <td>18-25 mts</td> </tr> <tr> <td>50 mts bars</td> <td>6-12 mts</td> <td>12-24 mts</td> <td>24-36 mts</td> <td>36-50 mts</td> </tr> </tbody> </table>	Jumper selector	$\frac{1}{4}$	$\frac{1}{2}$	$\frac{3}{4}$	full	25 mts bars	0-6 mts	6-12 mts	12-18 mts	18-25 mts	50 mts bars	6-12 mts	12-24 mts	24-36 mts	36-50 mts
Jumper selector	$\frac{1}{4}$	$\frac{1}{2}$	$\frac{3}{4}$	full												
25 mts bars	0-6 mts	6-12 mts	12-18 mts	18-25 mts												
50 mts bars	6-12 mts	12-24 mts	24-36 mts	36-50 mts												

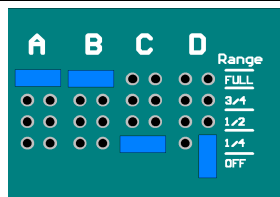

Fig. 16

Switch on and check

Once all the cabling have been done, it is necessary to check the correct installation and functioning of the system. After having switched on the system, wait for about ten seconds and than start to verify following the steps as outlined:

- 1) check the correct operational status of the Hub, checking that the led (Fig. 25) is lighted or blinking. If the led is does not lights up check the power supply wiring of the Hub
- 2) Check that the Hub doesn't show failure (led on hub lighted fix). In case failure shows check the wiring to the barriers, the correct setting of the jumpers of the range (Fig. 25) that are the ones that shows how many couples are connected to the Hub and also that the ID number of the barriers are correct.
- 3) If the Hub shows tamper alarm and all the caps have been already closes, than there is a anomalus closing of one or more caps. If instead some caps are still open, than it's correct that the tamper alarm goes on.

Now we can proceed with aligning of the barriers and it's normal that since they are not yet aligned that the Hub gives an alarm or disqualification.

Barriers alignment

In order to correctly couple the barrier we can proceed in two ways; with or without the tester. The tester (Fig. 19) it's an instrument that allows to check in a very deep way the behaviour of every single beam within a couple of barriers and is therefore ideal for this kind of trim. It is however possible to trim the couple by using the signalling alarm led which is inside each barrier. In both cases the Hub must be set in “TEST” mode. This will avoid some functionalities of the systems that would compensate the alignment's errors.

The alignment of the barrier through the tester are fully explained in the manual sold separately with the tester. Here below it is explained how to align the beams without the tester.

Before starting we must set the Hub on TEST and eliminate possible obstacles placed between the barriers.

Go to the first bar and take out the ROTAX cap to access the pivot that allows the alignment of the beams (Fig. 17).

Insert the rotation plug supplied with the bars and make a rough eye alignment (i.e. the beam of each

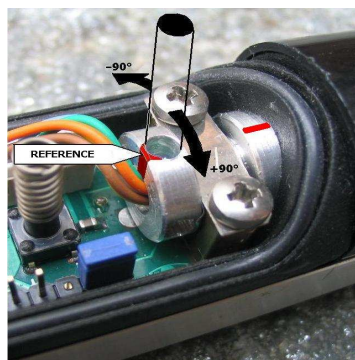

Fig. 17

bar should be directed toward the other bar) keeping in mind that the led emission (both the infrared and the visible ones) are in the direction on the sign placed on the ROTAX; do the same on the other bar. At this point check the alarm led positioned at 25 cm form the cap (do not be confused with the tamper one which is continuously lighted because the cap is open). Turn right and left the ROTAX cap in order to find the extreme alignment limits. When the alarm led flashes, it means that there is no alignment. For extreme limits, we intend the range covered with the led turned off. Once found the limits, turn the ROTAX in the middle of them. Do the same on the other bar. It is advisable to repeat this alignment twice if the distance of the two bars is longer than the half of the range of the barriers. Once the alignment is set, the bar led's must be turned off and closing the caps (ROTAX and NUMBERS) also the tamper alarm led should be switched off. Make the alignment for each couple of barriers connected to the hub and finally put the Hub in "OPERATE".

ACCESSORIES

The PHOTON system is endowed of different accessories to widen the array of its use and to simply the work of the installer. Here below you will find some with a brief description. The full instructions are given with the single product.

Interconnection Boxes - SCAP

The interconnection boxes (Fig. 22) allow to derivate the wire in two outputs for each couple of barrier. They are fully waterproof (IP 54) and have a tamper to protect them from tampering.

In order to use the tamper of the boxes (all in series between the various boxes) the bus 6 wire + shield cable must be used, while the one that goes to the bars is 4 wires + shield.



Figura 18

Tester - TBS

This is a tester (Fig. 19) to be used to optimize the alignment during the installation. It monitor in real time the reception of the signal. Thus by moving the ROTAX hinge you will obtain a perfect alignment of the beams. The tester will be connected to the dedicated connector placed in the ROTAX cap of the bars (Fig. 26). It is sufficient to connect to any of the bars to check the whole system. Though a selector you can select the couple of barriers and by setting the sensitivity you can analyze if the beams are correctly couple, is someone is too low or even faulty. In the tester also possible disqualification status are shown; this is useful when installing the barriers outside not only because you can verify the correct alignment but also if the distance between the couple is correctly set. The signal of "tamper" and "failure" will allow you to immediately find which bar is not properly installed. The tester is a very useful, versatile and of easy usage and it becomes indispensable for the installer that is facing quite complex installations. It is also very useful for simpler installations because it make the installation much faster dramatically cutting the time for aligning the barriers which is at the base of a correct functioning of the system.

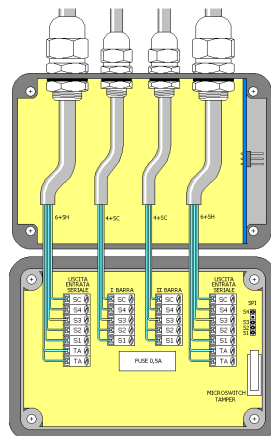
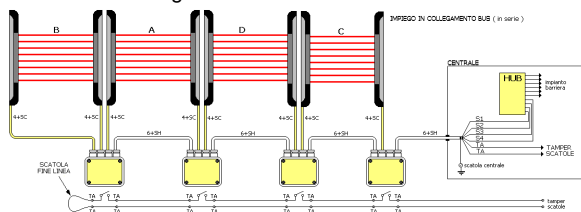
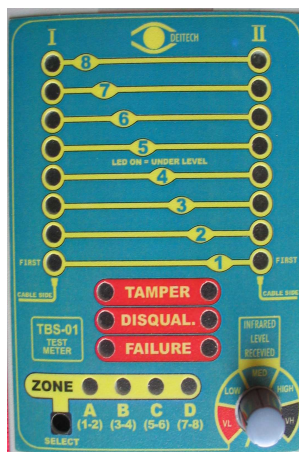

Fig. 19

The hub expansion – ME4

It's a card (Fig. 20) that has to be inserted and fixed to the hub. It allows to widen the potentiality of the system. It enable the multizone managing of the alarm and it allows through an RS 232 cable to connect the system to a PC. In this way you can remotely check the installation. For this purpose the card come along with a proprietary software completely developed by Deitech (Fig. 23). The software will monitor, analyze and record on a log all the messages given by the system.

On the base hub, there is only on alarm output for all the couple connected. With the expansion the output are increased to 4 (all separate), one for each couple installed. The common alarm output on the hub still works anyway.

The RS-232 output, through a dedicated adapter supplied, can be connected with a serial cable NULL-MODEM to a PC and through the supplied software it will be possible to visualize on the monitor the working status of the system.

The software will enable to log all the events with the exact timing in which the event occurred directly on the pc's hard disk. This will enable to keep a log of the events for many months, depending on the actual free space on the pc. Through a mask it's possible to quickly analyze the data logged. In this way you will very easily check if and when any event has occurred. Through a modem and a remote control software (ex. pcAnywhere ® o similar) you can monitor the system from remote.

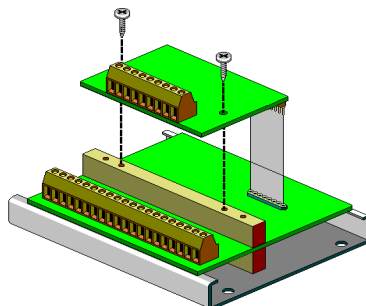

Fig. 20

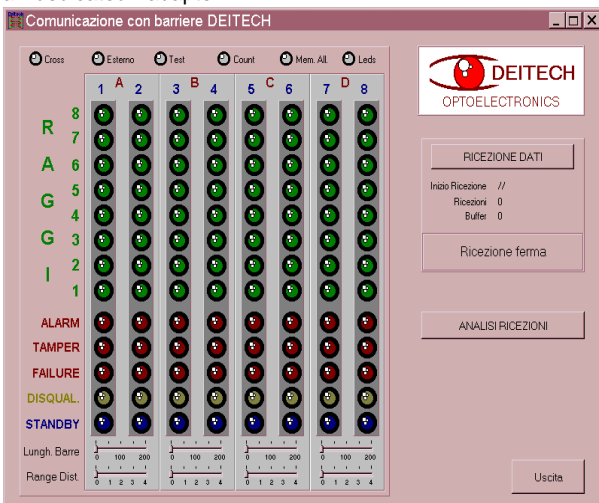

Fig. 21

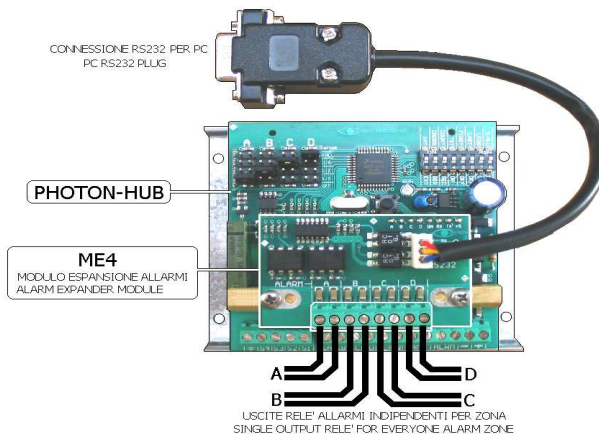

Fig. 22

MAXIMUM LENGTH ON THE MOST COMMON CONFIGURATION WITH STANDARD CABLE 4+SH / 6+SH

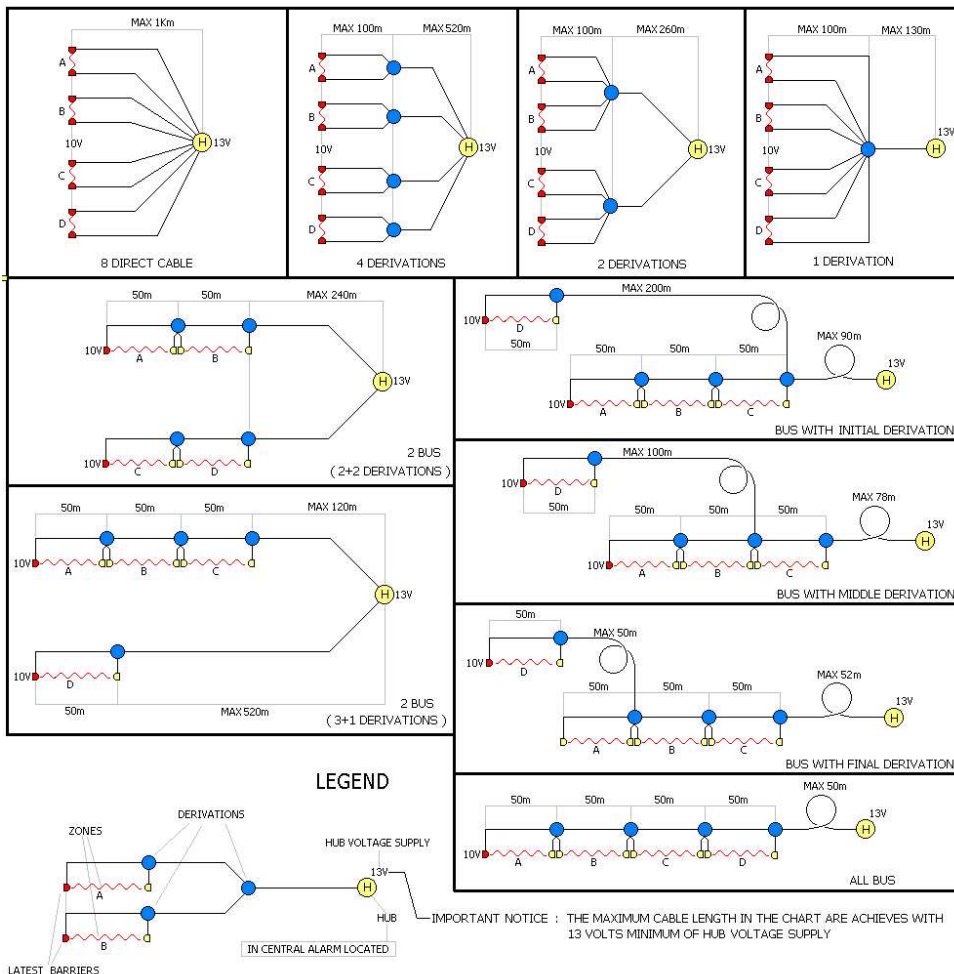

Fig. 23

HOW TO SET THE SYSTEM IN BUS MODE INTO 250m (750ft) FROM THE HUB WITH STANDARD CABLE

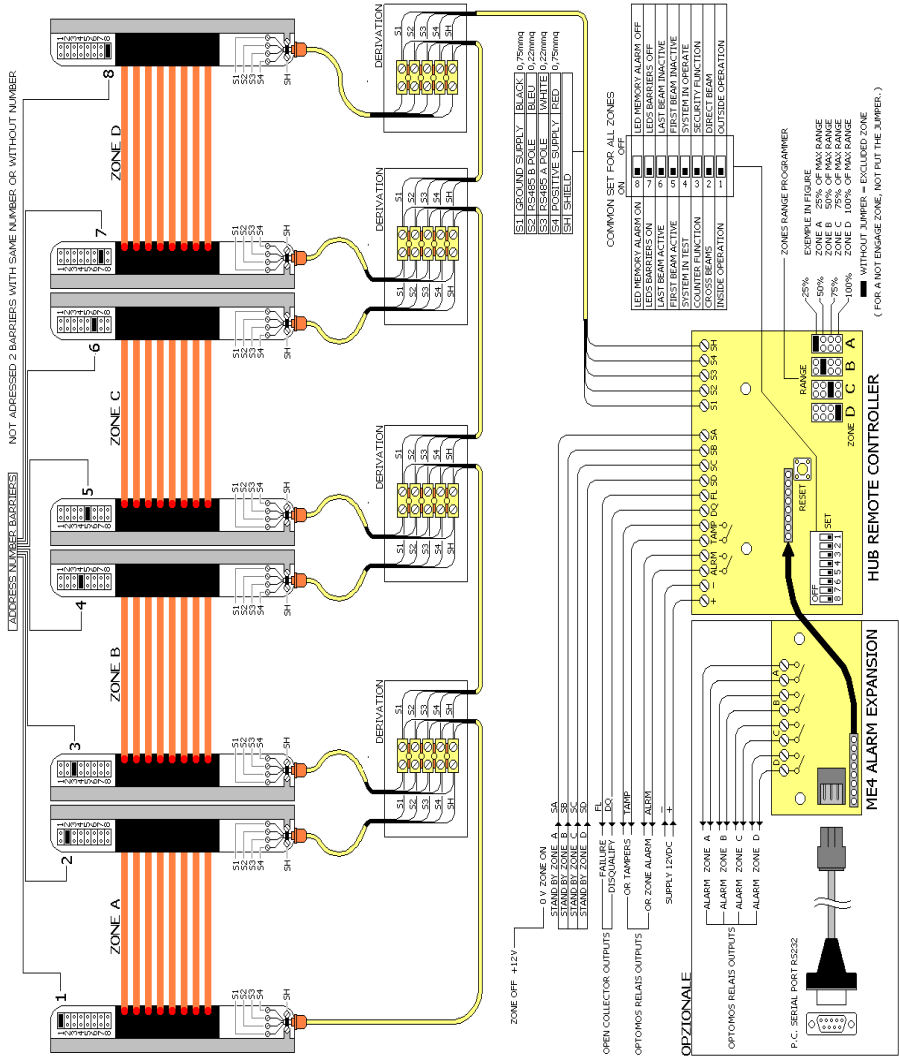

Fig. 24

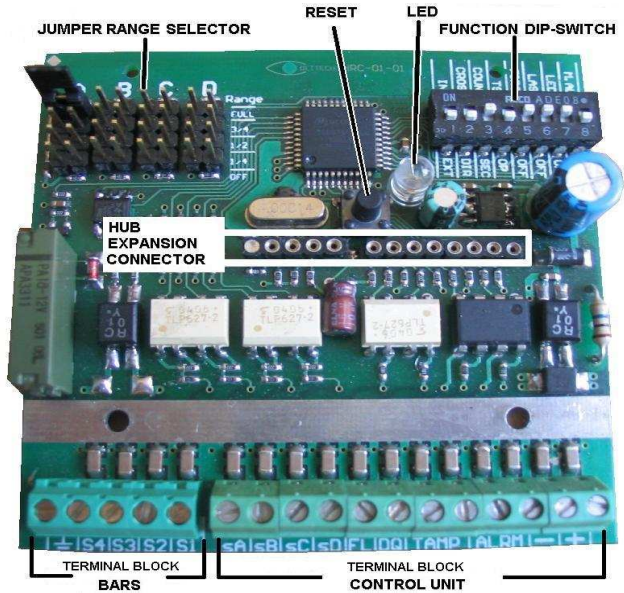
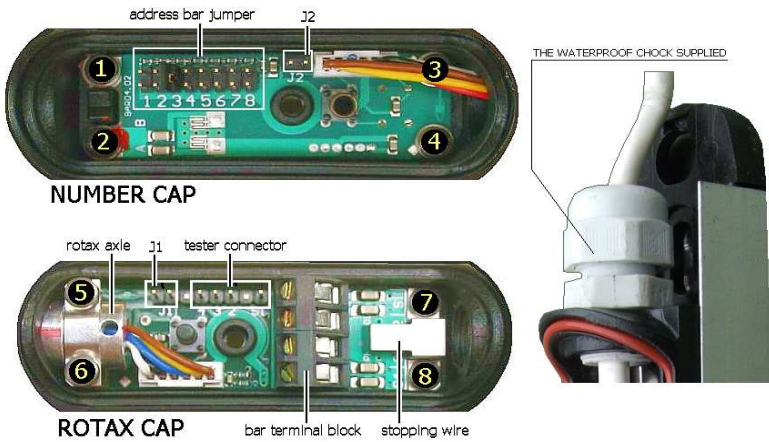

Fig. 25



NUMBER CAP

ROTAX CAP

THE WATERPROOF CHOCK SUPPLIED

①

CAREFUL :

②

NEVER MOVE THE SCREW (1:8)
INSIDE THE CAPS

OBLIGATORY CHOCK ASSEMBLING

THE DISREGARD OF THESE DIRECTIONS
CAUSE LOSS OF WARRANTY RIGHTS AND IP GRADE PROTECTION

Fig. 26

INSTALLATION CONNECTIONS TEST

PRIOR TO POWER THE HUB, OR TO CHECK MALFUNCTIONING DUE TO WORN OFF WIRINGS,
IT IS SUGGESTED TO CHECK THE EXACT CONNECTION OF THE BARRIERS TO THE HUB .

THE SHEETS ARE SHOWING THE RESISTIVE VALUES TO CHECK WITH A TESTER ON THE HUB TERMINAL BLOCK.

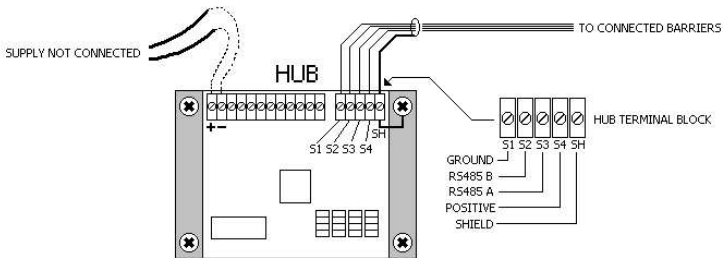

	<p>RS485 IMPEDANCE CHECK TOWARD GROUND</p> <p>8 BAR 5,5K 6 BAR 7,1K 4 BAR 10K 2 BAR 16,6K</p> <p style="text-align: right;">+/- 10%</p> <p>8 BAR 5,5K 6 BAR 7,1K 4 BAR 10K 2 BAR 16,6K</p> <p style="text-align: right;">+/- 10%</p> <p>RS485 IMPEDANCE CHECK TOWARD POSITIVE</p> <p>S4 / S2 = > 50 MOHM (OPEN CIRCUIT) S4 / S3 = > 50 MOHM (OPEN CIRCUIT)</p>												
	<p style="text-align: center;">IMPEDANCE CHECK RS485 POLES</p> <p>8 BAR 25 OHM + CABLE RESISTANCE 6 BAR 33 OHM + CABLE RESISTANCE 4 BAR 50 OHM + CABLE RESISTANCE 2 BAR 100 OHM + CABLE RESISTANCE</p> <table border="1" style="margin-left: auto; margin-right: auto;"> <thead> <tr> <th></th> <th>THICKNESS COPPER WIRE</th> <th>CABLE RESISTANCE FOR 100 METERS</th> </tr> </thead> <tbody> <tr> <td>STANDARD</td> <td>0.22 mmq</td> <td>14,5 OHM</td> </tr> <tr> <td>SPECIAL</td> <td>0.50 mmq</td> <td>6,4 OHM</td> </tr> <tr> <td>SPECIAL</td> <td>0.75 mmq</td> <td>4,3 OHM</td> </tr> </tbody> </table>		THICKNESS COPPER WIRE	CABLE RESISTANCE FOR 100 METERS	STANDARD	0.22 mmq	14,5 OHM	SPECIAL	0.50 mmq	6,4 OHM	SPECIAL	0.75 mmq	4,3 OHM
	THICKNESS COPPER WIRE	CABLE RESISTANCE FOR 100 METERS											
STANDARD	0.22 mmq	14,5 OHM											
SPECIAL	0.50 mmq	6,4 OHM											
SPECIAL	0.75 mmq	4,3 OHM											
	<p style="text-align: center;">IMPEDANCE CHECK POWER POLES</p> <p style="text-align: right;">> 50 MOHM (OPEN CIRCUIT)</p>												
	<p style="text-align: center;">IMPEDANCE CHECK TOWARD SHIELD</p> <p>S1 / SH 10 MOHM S2 / SH 10 MOHM S3 / SH 10 MOHM S4 / SH > 50 MOHM (OPEN CIRCUIT)</p>												

INFRARED ROD

RANGE	LENGTH
25m	EB 200-25 ----- EB 20-200
	EB 150-25 ----- EB 20-150
	EB 100-25 ----- EB 20-100
	EB 050-25 ----- EB 20 - 50
	EB 200-25 R ---- EB 20-200 R
50m	EB 200-50 ----- EB 40-200
	EB 150-50 ----- EB 40-150
	EB 100-50 ----- EB 40-100
	EB 050-50 ----- EB 40 - 50
	EB 200-50 R ---- EB 40-200 R
TECHNICAL CODE	
TRADE CODE	
WITH HEATER	

MOD	LENG.	WID.	THIC.	WEIG.	DOUBLE BEAMS	OPTICS ELEMENTS
EB 200 XX	2116 mm	28mm	32mm	1700g	8	32
EB 150 XX	1636 mm	28mm	32mm	1300g	6	24
EB 100 XX	1166 mm	28mm	32mm	950g	4	16
EB 50 XX	686 mm	28mm	32mm	550g	2	8

FEATURES FOR ALL MODELS

- MAX CONSUMPTION _____ 100mA
- BEAM TO BEAM _____ 250mm
- ALARM INTENS. REDUCTION [80% for 500mS ONE BEAM ONLY
80% for 100mS TWO BEAMS OR MORE
- DISQ. INTENS. REDUCTION _____ 50% IN 10 SEC.
- WAVE LENGHT _____ 940nm
- MAX RADIANT POWER _____ 3000mW/sterad. SINGLE BEAM
- WATERPROOF _____ IP 65
- PRESSURE COMPENSATOR _____ 2 GORETEX® MEMBRANE VENTS
- TAMPERS _____ 2 ANTIOPENING 2 ANTIREMOVAL
- LEDS _____ ALARM AND TAMPERS
- ADJUSTEMENTS _____ HORIZZONTAL +/- 90°
- POWER SUPPLY _____ 9 - 16V DC 100mA MAX
- OUTPUT _____ FULL DUPLEX RS485
- OPERATING TEMP. RANGE _____ EB XXX YY 0°C +60°C
EB XXX YY R -20°C +60°C WITH HEATER OPERATIVE
- EMC IMMUNITY : SEE HUB

HRC01

HUB (REMOTE CONTROLLER)

STAND BY : 4 ZONES INPUTS (A-B-C-D)

OPERATE = 0 VOLT OR FREE

STAND BY = +12V

ALARM AND TAMPERS : PHOTORELEAIS OUTPUTS

NORMAL = CONTACT CLOSED (20 OHM)

ALARM = CONTACT OPEN

FAILURE AND DISQUALIFY : OPEN COLLECTOR OUTPUTS

NORMAL = OPEN OR 12V

WARNING = CLOSED 0 VOLT

POWER SUPPLY _____ 9 -16V DC 900mA MAX (WITH 8 ROD EB200XX CONNECTED)

EMC IMMUNITY _____ BETTER OF : EN50130-4+A1+A2 EN61000-6-3 (2001) EN61000-6-1(2001)

LED _____ BLINK = SYSTEM OK FIX = SYSTEM FAILURE

RESET _____ MANUAL PUSCH BUTTON ON BOARD (TO ACTIVATE DIP SWITCH SETTINGS)

INSTALLATIONS _____ IN PROTECT BOX

DIP SWITCH SETTINGS FOR ALL ZONES

- ALARM MEMORY - ON / OFF
- RODS LEDS - ON / OFF
- FIRST BEAM - ON / OFF
- LAST BEAM - ON / OFF
- SYSTEM IN TEST / OPERATE
- COUNT MODE / SECURITY MODE
- CROSS BEAMS / DIRECT BEAMS
- INTERNAL USE / EXTERNAL USE

JUMPER SETTINGS FOR EVERYONE ZONE

4 DISTANCE RANGE = 1/4 1/2 3/4 FULL (of rod max range)

NOTICE : THE ZONE IS DISABLED WHEN THE JUMPER IS NOT CONNECTED

ADDED NOTES FOR THE HEATED BARRIERS

Structurally and conceptually identical to the infrared barrier, the heated infrared barrier differs only for the presence of a resistive element assembled for the whole length of the barrier. A built in thermostat automatically balance the internal temperature thus avoiding the ice formation on the surface whenever the outside temperature reaches the 0 degree Celsius. This could prevent the barriers to work properly.

The switching on of the thermostat and subsequently of the heater is visualized by a led positioned inside the bar close to the number cap.

The heated bars require an extra supply assured by an external AC power supply the connection being assured by two terminals positioned inside the number cap. (Fig. 1) opposed to the rotax cap.

The following scheme will show the minimum diameter of the wire to be used for a connection to a maximum distance of 50 mts from the power supply.

In any case the external diameter of the connection wire must not be more than 6,8mm

MODELL	VOLTAGE	COURRENT	POWER	WIRE DIAMETERI
EB-200R	20V AC 50-60Hz	2500mA	50W	1,5mm ²
EB-150R	15V AC 50-60Hz	2500mA	37,5W	1.5mm ²
EB-100R	10V AC 50-60Hz	2500mA	25,0W	1.5mm ²
EB-50R	5V AC 50-60Hz	2500mA	12,5W	1.5mm ²

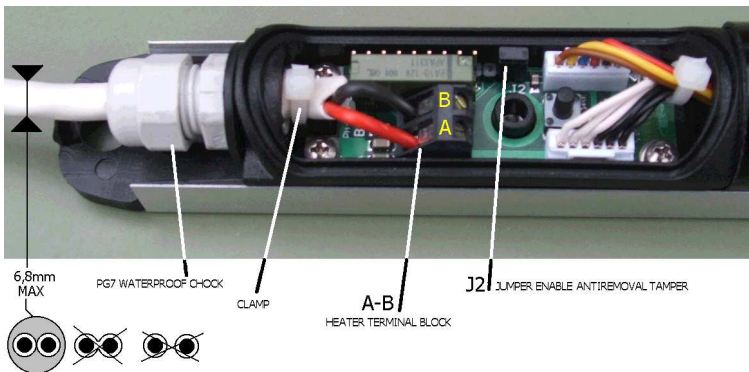

FIG. 1

CAUTION: In order to assure the IP protection it is mandatory to use wire with sheath. **DO NOT USE FLAT CABLE OR SINGLE WIRE**

WARNING: The AC power supply of the heaters must be a reinforced insulation type and must be protected against short circuits. Beside before the power supply we will have to put a main circuit breaker that allows to do maintenance work on the barriers or to totally deactivate the heating during summer time.

The product is guaranteed only if it is installed in a professional manner and in a state of the art following all the instructions given. No responsibility can be blamed on the manufacturer for damages deriving from bad installations and/or defective electrical connections.

HEATER BARRIERS ADDRESSING

The heated version differ from the base version for the addressing jumpers layout. In Fig. 2 it is clearly shown the modality for the coupling with the identity number. Be very careful in making this operation since the limited area on which you will operate can often cause mistakes.

Barrier addressing jumpers:

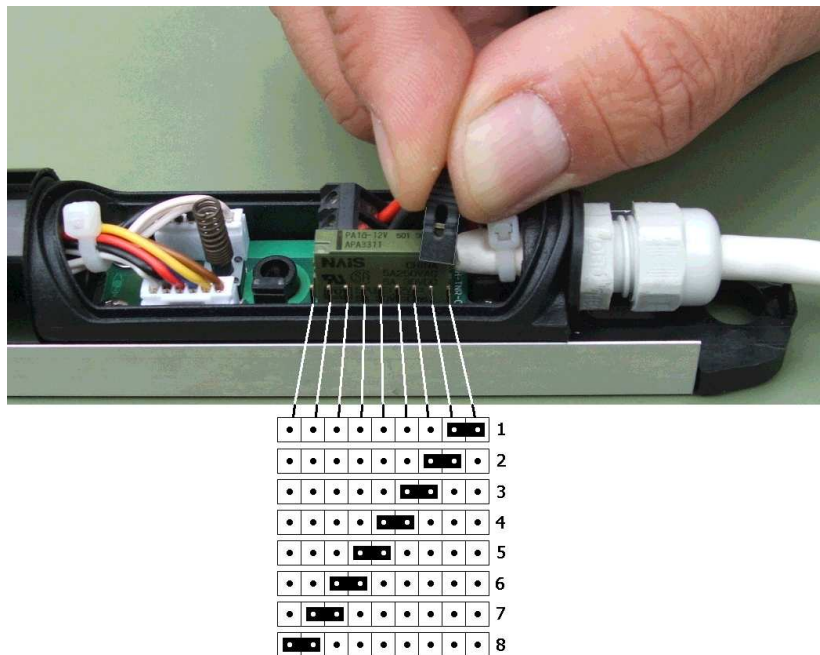

FIG. 2

DICHIARAZIONE DI CONFORMITA'
DECLARATION OF CONFORMITY



IL PRODUTTORE
THE MANUFACTURER DEITECH S.R.L. VIA CHAMBERY 79/10 TORINO-ITALY

DICHIARA CHE QUESTI PRODOTTI DECLARES THAT THESE PRODUCTS

BARRIERE INFRAROSSE PHOTON – PHOTON INFRARED BARRIERS

EB200-50-R	EB200-25-R	EB200-50	EB200-25
EB150-50-R	EB150-25-R	EB150-50	EB150-25
EB100-50-R	EB100-25-R	EB100-50	EB100-25
EB50-50-R	EB50-25-R	EB50-50	EB50-25

CONTROLLORE REMOTO – REMOTE CONTROLLER
HUB + ME4

SONO CONFORMI ALLE SEGUENTI DIRETTIVE EUROPEE
CONFORMS WITH THE FOLLOWING EUROPEAN DIRECTIVES

COMPATIBILITA' ELETTROMAGNETICA
ELECTROMAGNETIC COMPATIBILITY

EMC 89/336/CEE
EN 61000-6-1
EN 50130-4

SICUREZZA ELETTRICA
ELECTRIC SAFETY

LVD 73/23/CEE
EN 60950-1

TORINO - ITALY - 24-4-2006 VITO DISABATO DIRETTORE GENERALE
GENERAL MANAGER



VIA CHAMBERY 79/10 TORINO ITALY
TEL 011 704 867 – FAX 011 701 254
www.deitech.it info@deitech.it

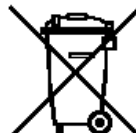

MAIN INSTALLATION STEPS

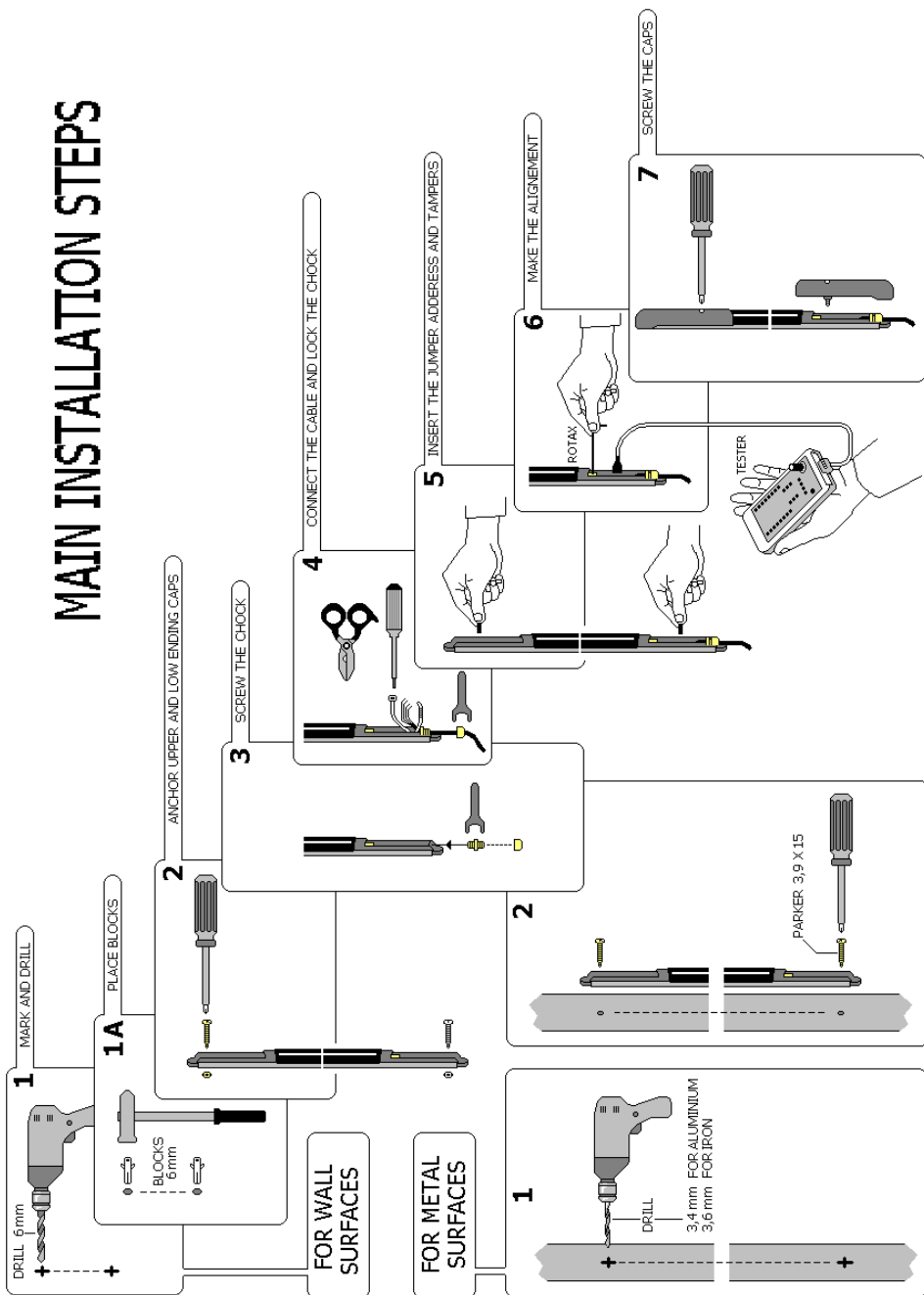

Esempio di installazione
su supporto metallico

installation example on
metallic base

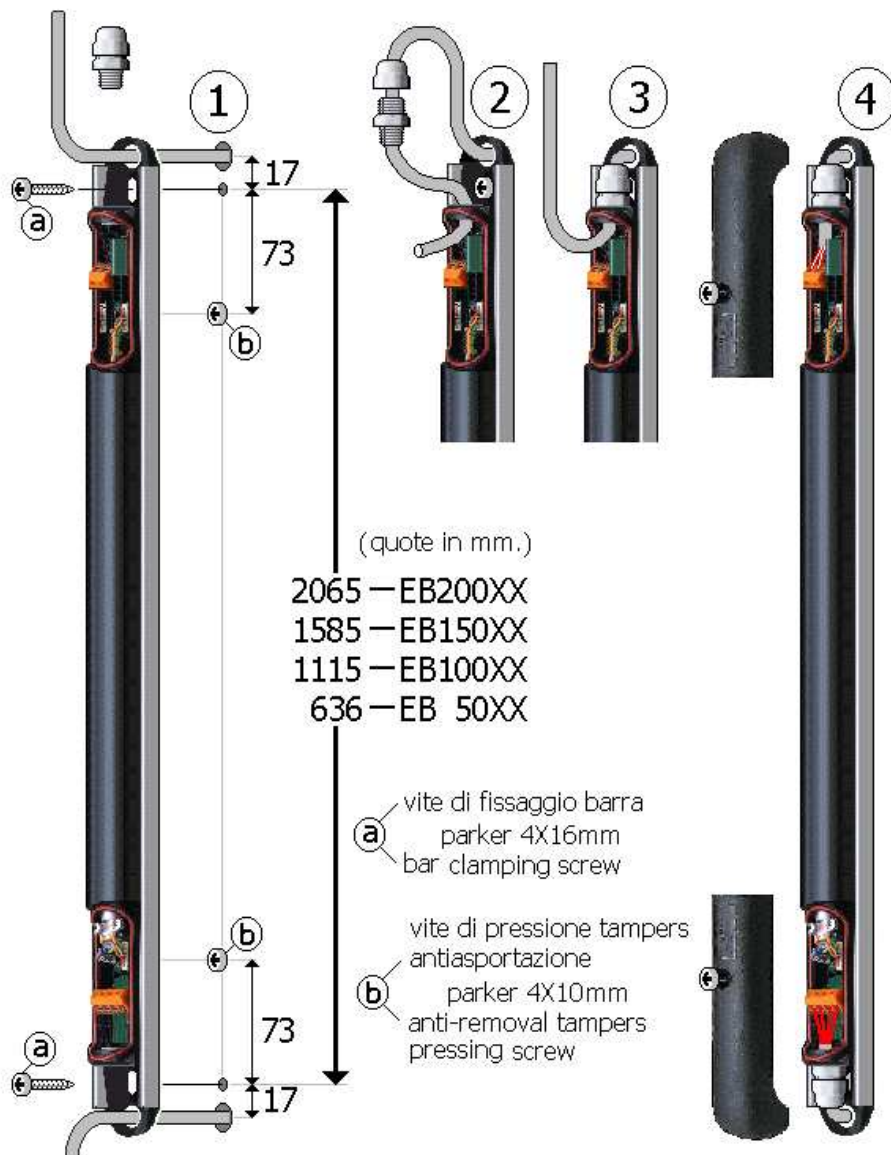

WASHING NOTICE

AVVERTENZE PER LA PULIZIA

YES

HAND WASH



NOT

HIGH
PRESSURE
WATER

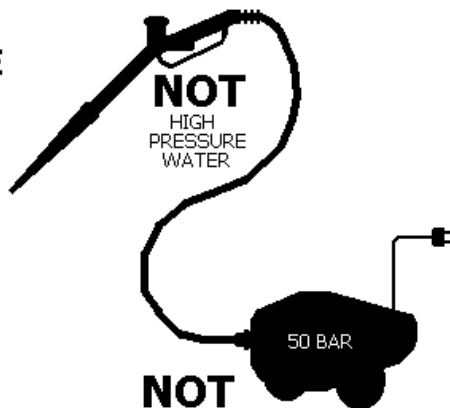

NOT

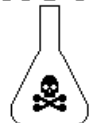

ALCOHOL
SOLVENT
ACID

USARE SOLO ACQUA E SAPONE NEUTRO

NON USARE IDROPULITRICI E PRODOTTI CHIMICI

MOUNTING NOTICE

AVVERTENZE DI MONTAGGIO

